

INCH-POUND
MIL-DTL-28754/17D
15 October 2001
SUPERSEDING
MIL-C-28754/17C
13 December 1982

DETAIL SPECIFICATION

CONNECTORS, ELECTRICAL, MODULAR, CONNECTOR ASSEMBLY,
TYPE V, STYLE I, CONTACT TAILS ON .100 CENTERS

This specification is approved for use by all Departments
and Agencies of the Department of Defense.

The complete requirements for acquiring the connector assemblies described
herein shall consist of this specification and the latest issue of MIL-C-28754.

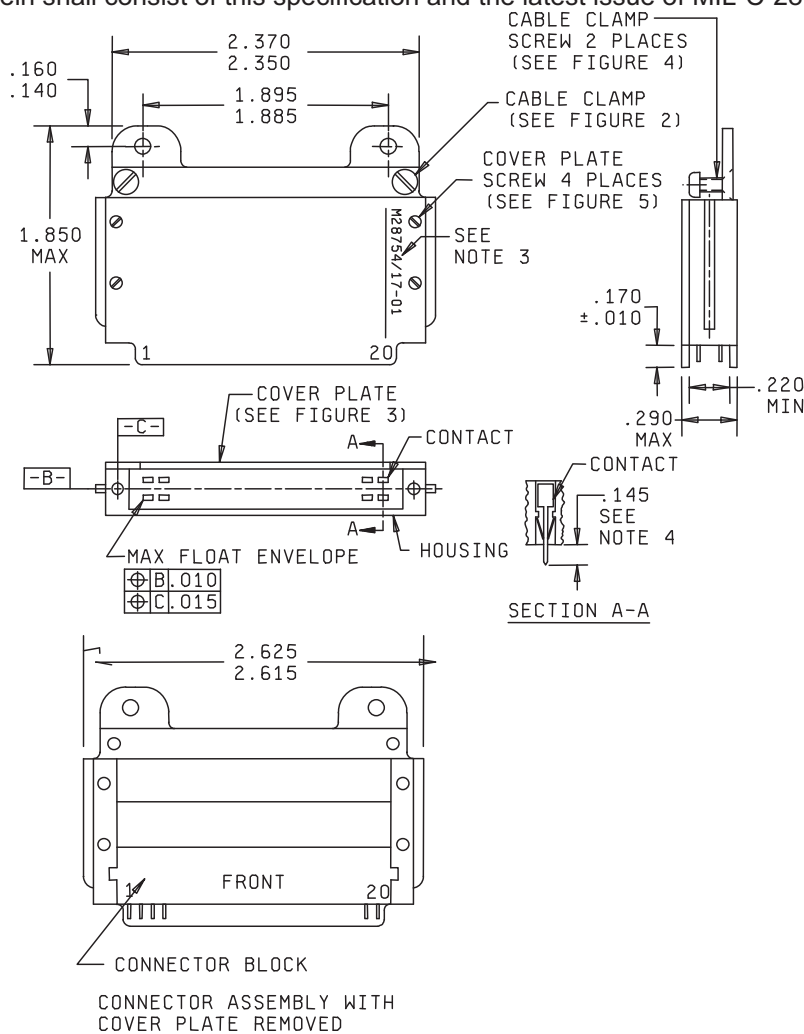

FIGURE 1. Connector assembly type V.

MIL-DTL-28754/17D

Inches	mm
.010	0.25
.015	0.38
.140	3.56
.145	3.68
.160	4.06
.170	4.32
.220	5.59
.290	7.37
1.850	46.99
1.885	47.88
1.895	48.13
2.350	59.59
2.370	60.20
2.615	66.42
2.625	66.70

NOTES:

1. Dimensions are in inches.
2. Metric equivalents are given for general information only.
3. Mark this area in contrasting color characters .30 inch (7.62 mm) high maximum. Marking can be vertical or horizontal.
4. This dimension applies after assembly of contacts.
5. Component parts to be supplied unassembled.
6. Unless otherwise specified tolerance are ± 0.005 inch (0.13 mm) on three place decimals and $\pm 2^\circ$ on angle.

FIGURE 1. Connector assembly type V - Continued.

MIL-DTL-28754/17D

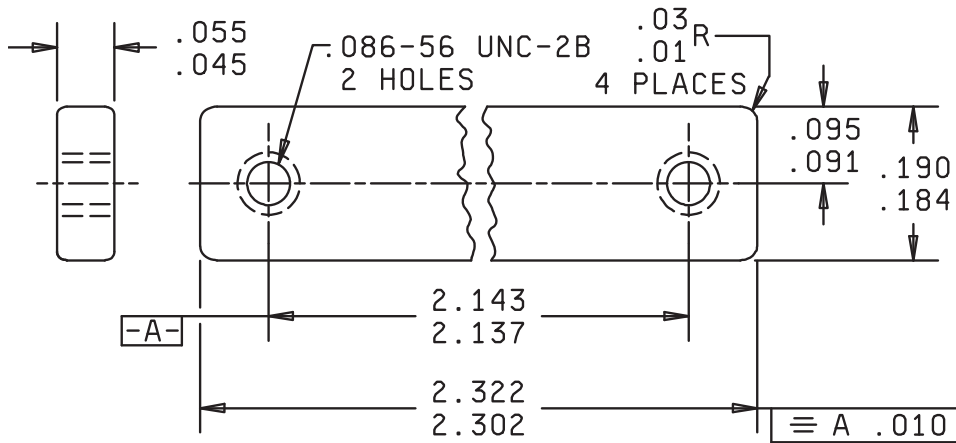

Inches	mm	Inches	mm
.010	0.25	.184	4.67
.03	0.76	.190	4.83
.045	1.14	2.137	54.30
.055	1.40	2.143	54.40
.086	2.18	2.302	58.50
.091	2.31	2.322	59.00
.095	2.41		

NOTES:

1. Dimensions are in inches.
2. Metric equivalents are given for general information only.
3. Break sharp edges .015 inch (0.38 mm) maximum.
4. Material: Stainless steel in accordance with ASTM A240, type 304, annealed, finish in accordance with ASTM A480 No. 2B. Magnetic permeability shall not be higher than 1.02 at 200 oersteds (air equal to 1.00).
5. Passivate in accordance with SAE AMS-QQ-P-35, type optional.
6. Unless otherwise specified tolerances are $\pm .005$ inch (0.13 mm) for three place decimals and $\pm .01$ inch (0.25 for two place decimals). For angles the specified tolerance is $\pm 2^\circ$.

FIGURE 2. Cable clamp MS14060.

MIL-DTL-28754/17D

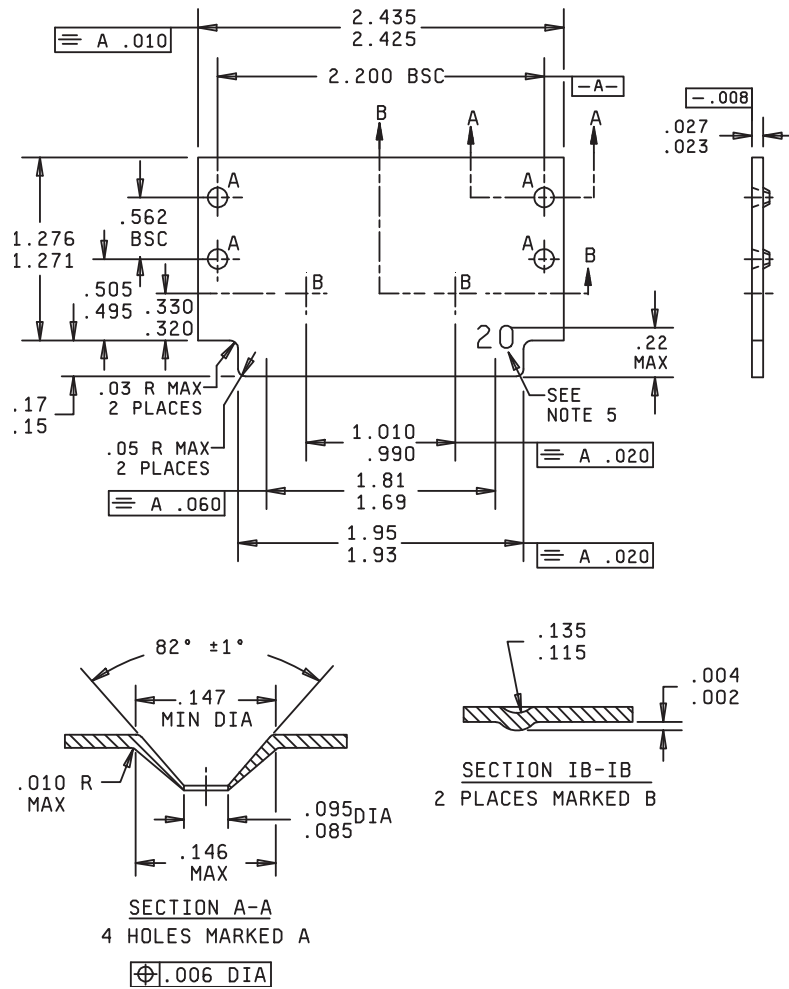

Inches	mm	Inches	mm	Inches	mm
.002	0.05	.095	2.41	.562	14.27
.004	0.10	.115	2.92	.990	25.15
.006	0.15	.135	3.34	1.010	25.65
.008	0.20	.146	3.71	1.271	32.28
.010	0.25	.147	3.73	1.276	32.41
.020	0.51	.15	3.8	1.69	42.93
.023	0.58	.17	4.3	1.81	45.97
.027	0.69	.22	5.6	1.93	49.02
.03	0.76	.320	8.13	1.95	49.53
.05	1.27	.330	8.38	2.200	55.88
.060	1.50	.495	12.57	2.425	61.59
.085	2.16	.505	12.83	2.435	61.85

FIGURE 3. Cover plate MS14061.

MIL-DTL-28754/17D

Type	Finish	Marking
A	Anodize in accordance with MIL-A-8625, type 2, dyed black.	Mark characters .06 inch (1.52 mm) high with white epoxy ink, in accordance with MIL-C-28754.
B	Anodize in accordance with MIL-A-8625, type 2, dyed red.	Mark characters .06 inch (1.52 mm) high with black epoxy ink, in accordance with MIL-C-28754.

NOTES:

1. Dimensions are in inches.
2. Metric equivalents are given for general information only.
3. Break sharp edges .005 inch (0.13 mm) maximum.
4. Material: Aluminum alloy in accordance with SAE AMS-QQ-A-250F, H32, or AA 5052, H32.
5. Marking and finish per table.
6. Unless otherwise specified tolerances are $\pm .005$ inch (0.13 mm) for three place decimals and $\pm .01$ inch (0.25 for two place decimals). For angles the specified tolerance is $\pm 2^\circ$.

FIGURE 3. Cover plate MS14061 - Continued.

MIL-DTL-28754/17D

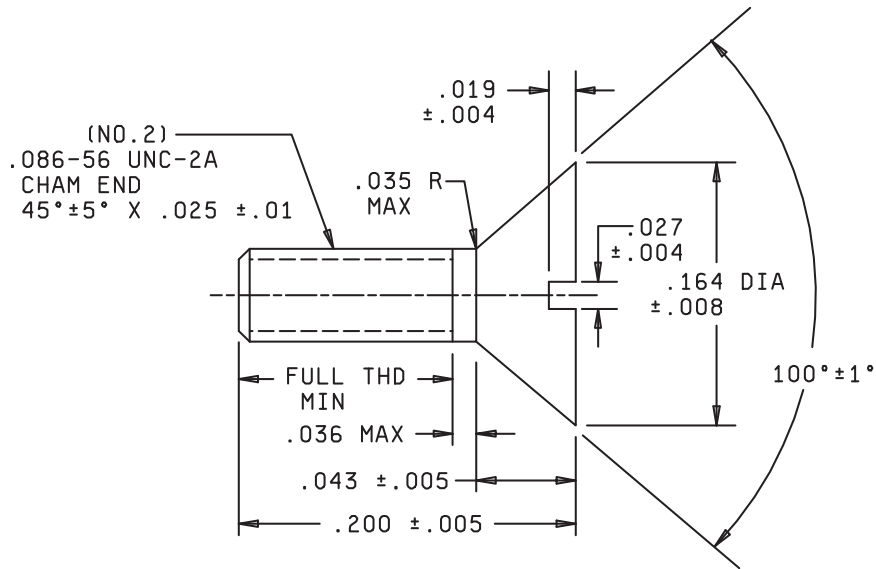

Inches	mm
.004	0.10
.005	0.13
.008	0.20
.01	0.25
.019	0.48
.025	0.64
.027	0.69
.035	0.89
.036	0.91
.043	1.09
.164	4.17
.200	5.08

NOTES:

1. Dimensions are in inches.
2. Metric equivalents are given for general information only.
3. Break sharp edges .005 inch (0.13 mm) maximum.
4. Material: Steel in accordance with ASTM A 582, type 303 or 303Se, condition annealed.
5. Passivate in accordance with SAE AMS-QQ-P-35, type IV.
6. Inside corners: .005 inch (0.13 mm) R maximum.
7. Unless otherwise specified tolerances are ± .005 inch (0.13 mm) for three place decimals and ± .01 inch (0.25 for two place decimals). For angles the specified tolerance is ± 2°.

FIGURE 4. Flat head screw - cable clamp (.200) MS14066.

MIL-DTL-28754/17D

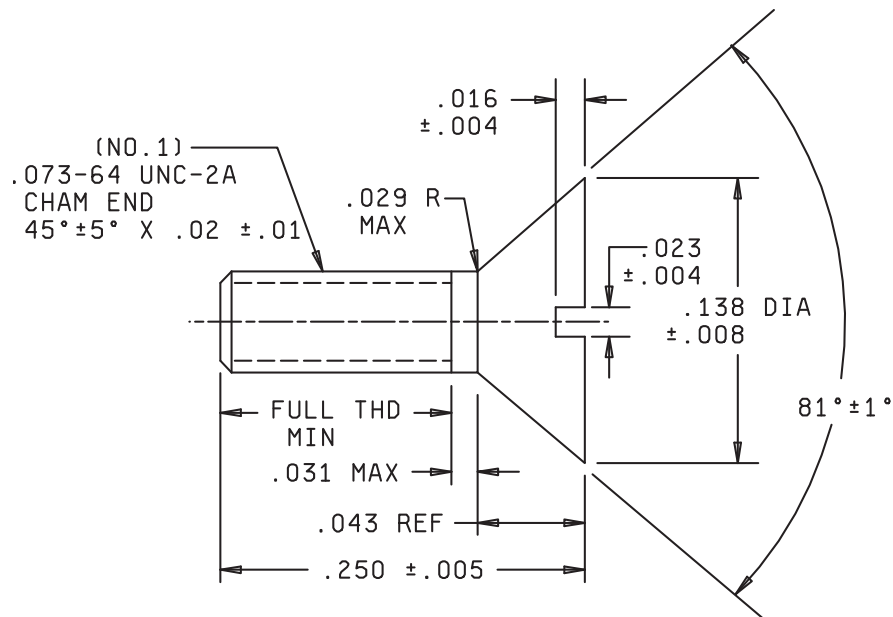

Inches	mm
.004	0.10
.005	0.13
.008	0.20
.01	0.25
.016	0.41
.02	0.51
.023	0.58
.029	0.74
.031	0.79
.043	1.09
.073	1.85
.138	3.51
.250	6.35

NOTES:

1. Dimensions are in inches.
2. Metric equivalents are given for general information only.
3. Break sharp edges .005 inch (0.13 mm) maximum.
4. Material: Steel in accordance with ASTM A 582, type 303 or 303Se, condition annealed.
5. Passivate in accordance with SAE AMS-QQ-P-35, type IV.
6. Inside corners: .005 inch (0.13 mm) R maximum.
8. Unless otherwise specified tolerances are $\pm .005$ inch (0.13 mm) for three place decimals and $\pm .01$ inch (0.25 for two place decimals). For angles the specified tolerance is $\pm 2^\circ$.

FIGURE 5. Flat head screw - cover plate (.250) MS14065.

MIL-DTL-28754/17D

REQUIREMENTS:

Dimensions and configuration: In accordance with figures 1 through 5.

Applicable connector block: In accordance with MIL-C-28754/16.

Applicable contact assembly: In accordance with MIL-C-28754/15.

Applicable cable clamp: See figure 2.

Applicable cover plate: See figure 3.

Applicable cable clamp screw: See figure 4.

Applicable cover plate screw: See figure 5.

Contact installing tool: See MIL-I-81969/2.

Contact removal tool: See MIL-I-81969/3.

Marking in accordance with MIL-C-28754, figure 1, and table I.

Military Part or Identifying Number (PIN):

M28754/17- (dash number from table I).

TABLE I. Dash numbers and characteristics.

Dash number	Connector	M28754/49 Housing type	Cover plate type (see figure 3)
01	M28754/16-01	A	A
02	M28754/16-01	B	B
03	M28754/16-01	C	A
04	M28754/16-02	A	A

Individual piece part ordering PIN's:

Cable clamp (see figure 2) PIN: MS14060
 Cable clamp screw (see figure 4) PIN: MS14066
 Cover plate (see figure 3) PIN: MS14061
 Cover plate screw (see figure 5) PIN: MS14065

Supersession data: This specification includes the requirements of Navy (10001) drawing number 2826728.

Qualification testing: Perform the applicable tests as specified in MIL-C-28754 and the appendix thereto.

Extended qualifications: Qualifications of M28754/17-01, /17-02, /17-03, or /17-04 extends qualifications to other products as specified in the appendix to MIL-C-28754.

MIL-DTL-28754/17D

CONCLUDING MATERIAL

Custodians:

Army - CR
Navy - EC
Air Force - 11
DLA - CC

Review activities:

Army - AR, MI
Navy - AS, MC, YD
Air Force - 19

Preparing activity:

NAVY - NW

Agent

DLA - CC

(Project Number 5935-4338)