

Product description	M12 Female cable connector, Contacts: 4, 4.0-6.0 mm, unshielded, screw clamp, IP67, UL
Area	M12-A series 713
Part no.	99 0430 14 04

Illustration

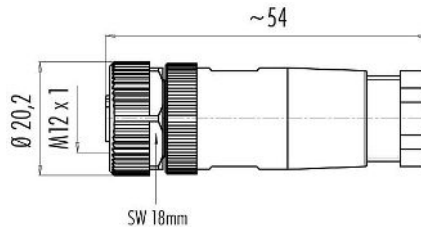

Scale drawing



Contact arrangement (Plug-in side)

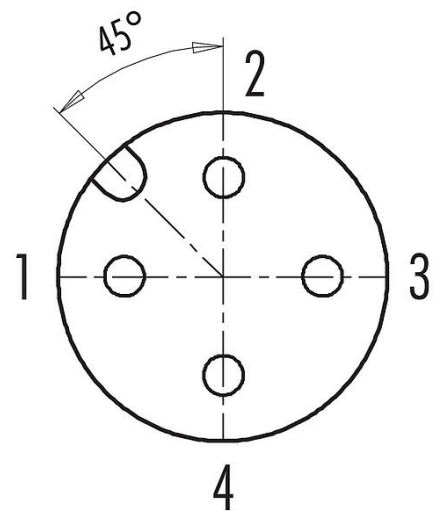

You can find the component part drawing and assembly instructions on the next page.

Technical data

General features

Part no.	99 0430 14 04
Connector design	Female cable connector
Type standard	DIN EN 61076-2-101
Version	Connector socket straight
Connector locking system	screw
Termination	screw clamp
Degree of protection	IP67
Cross-sectional area	max. 0.75 mm ² / AWG 18
Cable outlet	4.0-6.0 mm
Temperature range from/to	-40 °C / 85 °C
Mechanical operation	> 50 Mating cycles
Weight (g)	23.04
Customs tariff number	85369010
Country of Origin	DE

Electrical parameters

Rated voltage	250 V
Rated impulse voltage	2500 V
Rated current	4 A (3 A UL)
Insulation resistance	> 10 ¹⁰ Ω

Product data sheet

Automation technology - Sensors and actuators



Product description	M12 Female cable connector, Contacts: 4, 4.0-6.0 mm, unshielded, screw clamp, IP67, UL
-	-
Area	M12-A series 713
Part no.	99 0430 14 04

Pollution degree	3
Overvoltage category	II
Insulating material group	III
EMC compliance	unshielded

Material

Housing material	PA
Contact body material	PA
Contact material	CuZn (brass)
Contact plating	CuSnZn (Optalloy)
Locking material	Zinc die-cast nickel-plated
REACH SVHC	CAS 96-45-7 (Imidazolidine-2-thione) CAS 7439-92-1 (Lead)
SCIP number	0176753f-f267-4c49-a188-ffa72ed91fdc

Authorization/approvals

Approvals	UL
-----------	----

Classifications

eCl@ss 11.1	27-44-01-02
ETIM 9.0	EC002635

Declarations of conformity

Low Voltage Directive	2014/35/EU (EN 60204-1:2018;EN 60529:1991)
-----------------------	--

Product description	M12 Female cable connector, Contacts: 4, 4.0-6.0 mm, unshielded, screw clamp, IP67, UL
Area	M12-A series 713
Part no.	99 0430 14 04

Assembly instructions

1. Bead pressing screw, pinch ring, seal and sleeve to cable.
2. Dismantle cable.
3. Strip and screw on single wires:
4, 5 pole: 0.4 Nm, 8 pole: 0.2 Nm.
4. Screw sleeve to male/female insert.
5. Push seal and pinch ring into sleeve.
6. Tighten pressing screw.

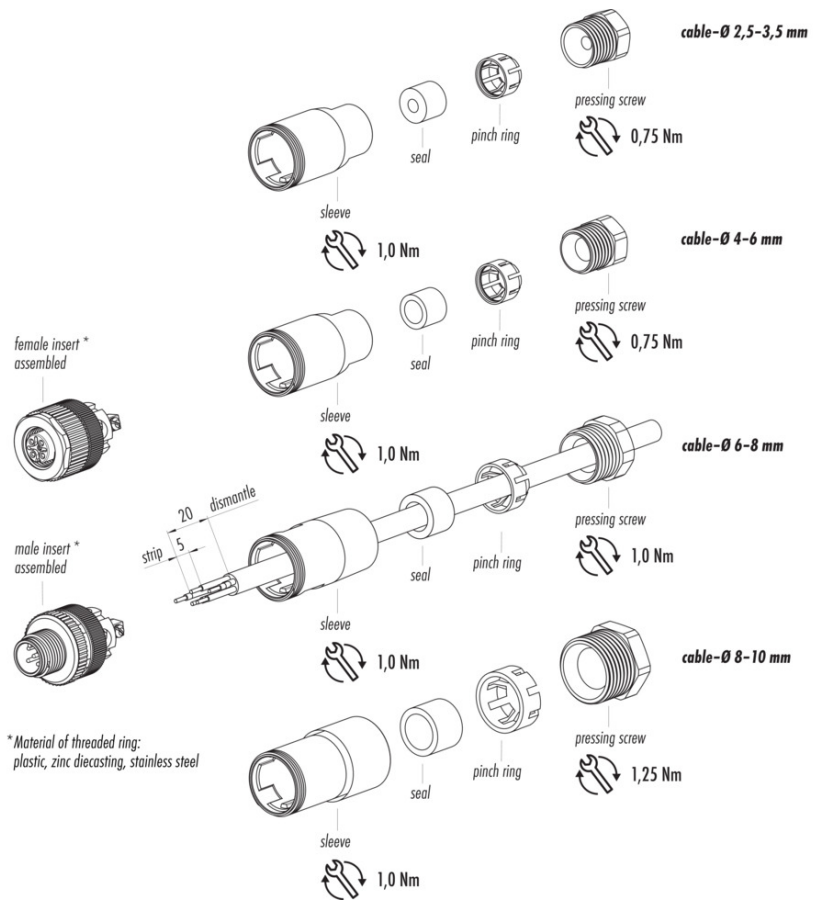

Product description	M12 Female cable connector, Contacts: 4, 4.0-6.0 mm, unshielded, screw clamp, IP67, UL
-	-
Area	M12-A series 713
Part no.	99 0430 14 04

Component part drawing

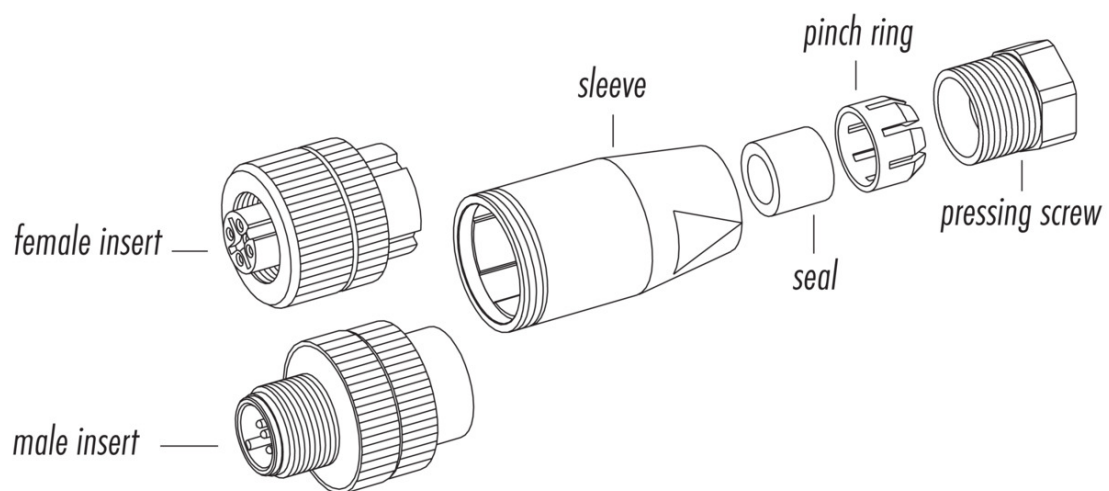

material of locking rings: plastic, zinc diecast, stainless steel

Product description	M12 Female cable connector, Contacts: 4, 4.0-6.0 mm, unshielded, screw clamp, IP67, UL
-	-
Area	M12-A series 713
Part no.	99 0430 14 04

General Disclaim Notice

The connector must not be plugged or unplugged under load. Non-observance and improper use can result in personal injury.

The connectors have been developed for applications in plant engineering, control and electrical equipment construction. The user is responsible for checking whether the connectors can also be used in other areas of application.

To protect against unintentional opening of the connector, the thread between the housing and the connector head must be secured with a suitable cyanoacrylate adhesive when used in circuits with voltages dangerous to the touch. This does not apply to connectors used in SELV and PELV circuits according to IEC 61140 (EN 61140, VDE 0140-1).

Connectors which are used in circuits with voltages dangerous to the touch may only be installed and used by, or under the supervision of, persons with electrical engineering training, taking into account the applicable regulations and standards.

Plug connectors with enclosure protection IP67 and IP68 are not suitable for use under water. When used outdoors, the plug connectors must be protected separately against corrosion. For further information on the IP protection classes, please refer to the "Technical Information" download centre.

To lock the cable connector with the device connector, the threaded ring is tightened "hand-tight" (approx. 60 cNm).