

Product data sheet

Automation technology - Data transmission



Product description	Female panel mount connector, Contacts: 4, unshielded, THT, IP67, UL, PG 9, front fastened
Area	M12-D series 876
Part no.	09 3732 90 04

Insulating material group	II
EMC compliance	unshielded

Material

Housing material	Zinc die-cast nickel-plated
Contact body material	PA (UL94 V-0)
Contact material	CuZn (brass)
Contact plating	Au (gold)
Locking material	CuZn (brass)
REACH SVHC	CAS 7439-92-1 (Lead)
SCIP number	2ffa8a28-6621-4f12-a136-f101a0a118ae

Authorization/approvals

Approvals	UL
-----------	----

Classifications

eCl@ss 11.1	27-44-01-09
ETIM 9.0	EC003569

Assembly instructions / Panel cut-out

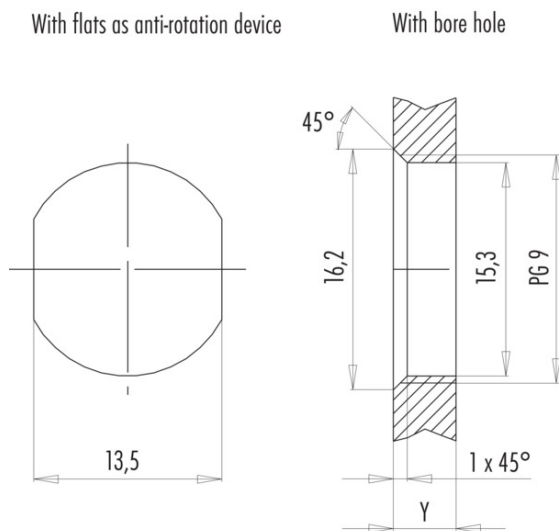

Installation direction: o-ring sits on chamfer.

Tightening moment

Metall housing/Plastic housing 1,25 Nm

Thickness of wall Y (mm)		
Version	min (mm)	max (mm)
Fastened from rear	2	3,5
Front fastened	2	4,5
positioning possible ¹⁾	2	3,5
Screw clamp	2	3,5
Thread M12 x 1	2	3,0
Thread M14 x 1 ²⁾	³⁾ 1,5/ ⁴⁾ 2	6,5

Notes

- ¹⁾ Do not attach a chamfer
- ²⁾ Wall thickness:
use nut 38 5385 100 001 up to 1,5 mm,
>1,5 mm cut thread
- ³⁾ Nut
- ⁴⁾ Thread in wall of housing

Product data sheet

Automation technology - Data transmission



Product description	Female panel mount connector, Contacts: 4, unshielded, THT, IP67, UL, PG 9, front fastened
-	-
Area	M12-D series 876
Part no.	09 3732 90 04

General Disclaim Notice

The connector must not be plugged or unplugged under load. Non-observance and improper use can result in personal injury.

The connectors have been developed for applications in plant engineering, control and electrical equipment construction. The user is responsible for checking whether the connectors can also be used in other areas of application.

Plug connectors with enclosure protection IP67 and IP68 are not suitable for use under water. When used outdoors, the plug connectors must be protected separately against corrosion. For further information on the IP protection classes, please refer to the "Technical Information" download centre.