

Product description	M12 Female panel mount connector, Contacts: 4, unshielded, solder, IP68, UL, PG 9, front fastened
Area	M12-A series 763
Part no.	86 0532 1002 00004

Illustration

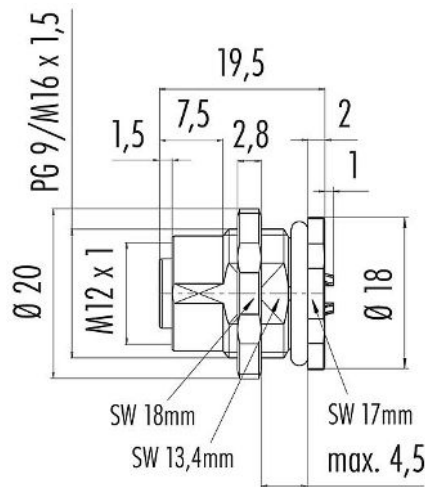

Scale drawing



Contact arrangement (Plug-in side)

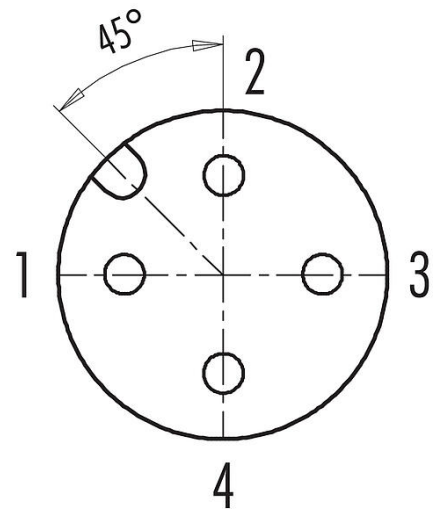

You can find the assembly instructions on the next page.

Technical data

General features

Part no.	86 0532 1002 00004
	Alternative part no.: 09 3432 216 04
Notice	Please note that, due to the change from the old to the new order number, there may be deviations in the technical specifications. For questions about product details, please use the 'Contact Customer Service' form on the right.
Connector design	Female panel mount connector
Type standard	DIN EN 61076-2-101
Version	Connector socket straight
Connector locking system	screw
Termination	solder
Degree of protection	IP68
Cross-sectional area	0.34 mm ² / AWG 22
Temperature range from/to	-40 °C / 85 °C
Mechanical operation	> 100 Mating cycles
Weight (g)	11.47
Customs tariff number	85369010
Country of Origin	DE

Electrical parameters

Rated voltage	250 V
Rated impulse voltage	2500 V

Product description	M12 Female panel mount connector, Contacts: 4, unshielded, solder, IP68, UL, PG 9, front fastened
Area	M12-A series 763
Part no.	86 0532 1002 00004

Rated current	4 A (3 A UL)
Insulation resistance	> 10 Ω
Pollution degree	3
Overvoltage category	II
Insulating material group	III
EMC compliance	unshielded

Material

Housing material	Zinc die-cast nickel-plated
Contact body material	PA black
Contact material	CuSn (bronze)
Contact plating	Au (gold)
REACH SVHC	CAS 7439-92-1 (Lead)
SCIP number	f24fe704-5f60-4f75-9f67-b917c0b2dff

Authorization/approvals

Approvals	UL
-----------	----

Classifications

ETIM 9.0	EC003569
----------	----------

Assembly instructions / Panel cut-out

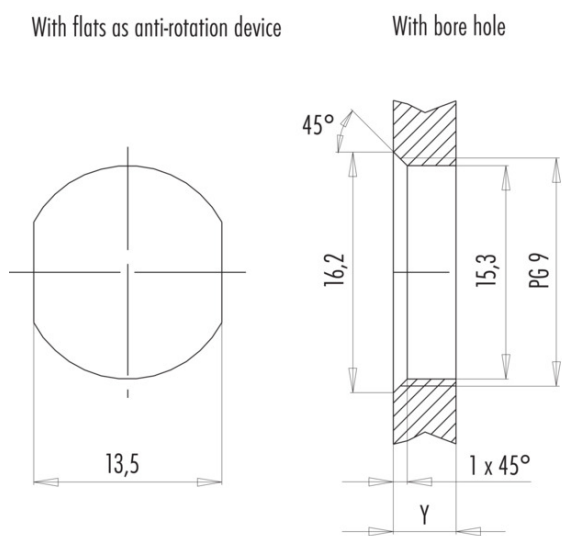

Installation direction: o-ring sits on chamfer.

Tightening moment

Metall housing/Plastic housing 1,25 Nm

Thickness of wall Y (mm)		
Version	min (mm)	max (mm)
Fastened from rear	2	3,5
Front fastened	2	4,5
positioning possible ¹⁾	2	3,5
Screw clamp	2	3,5
Thread M12 x 1	2	3,0
Thread M14 x 1 ²⁾	³⁾ 1,5/ ⁴⁾ 2	6,5

Notes

- ¹⁾ Do not attach a chamfer
- ²⁾ Wall thickness:
use nut 38 5385 100 001 up to 1,5 mm,
>1,5 mm cut thread
- ³⁾ Nut
- ⁴⁾ Thread in wall of housing

Product description	M12 Female panel mount connector, Contacts: 4, unshielded, solder, IP68, UL, PG 9, front fastened
-	-
Area	M12-A series 763
Part no.	86 0532 1002 00004

General Disclaim Notice

The connector must not be plugged or unplugged under load. Non-observance and improper use can result in personal injury.

The connectors have been developed for applications in plant engineering, control and electrical equipment construction. The user is responsible for checking whether the connectors can also be used in other areas of application.

The user must take suitable safety precautions to ensure that the connector cannot be accidentally disconnected.

Plug connectors with enclosure protection IP67 and IP68 are not suitable for use under water. For further information on the IP protection classes, please refer to the "Technical Information" download centre.