

Product Area	Male angled connector, cable outlet 6-7,8 mm M16 connectors IP 67	serie 423	Pole	7
			Article number	99 5625 79 07

illustration

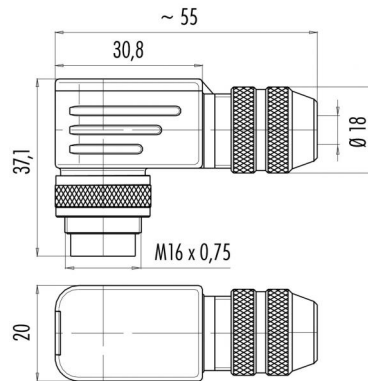

scale drawing



Contact Arrangement

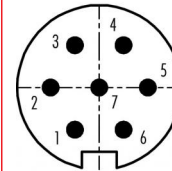

	X	Y
1	-1,75	-3,03
2	-3,50	0,00
3	-1,75	3,03
4	1,75	3,03
5	3,50	0,00
6	1,75	-3,03
7	0,00	0,00

Attenuation characteristic

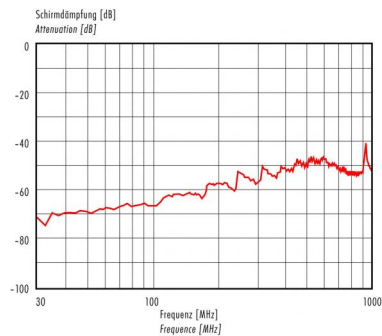

You can find the item description and assembly instruction on the next page.

Technical data

Common values

Connector Design	Male angled cable connector
Connector locking system	Screw
Termination	solder
Wire gauge (mm)	0,75 mm ²
Wire gauge (AWG)	20
Cable outlet	6 - 8 mm
Upper temperature	+95 °C
Lower temperature	-40 °C

Material

Material of contact	CuZn (brass)
Contact plating	Au (gold)
Material of contact body	PBT (UL 94 V-0)
Material of housing	CUZn (brass nickel plated)

Cable data

Contacts 7, male angled connector, shieldable, cable outlet 6 - 8 mm, gold plated contacts

Electrical values

Rated voltage	125 V
Rated impulse voltage	800 V
Pollution degree	1
Overvoltage category	I
Material group	III
Rated current (40°C)	5 A
Volume resistivity	≤ 3 mΩ
EMV compliance	shielded
Degree of protection	IP 67
Mechanical operation	>500 mating cycles



Product Male angled connector, cable outlet 6-7,8 mm
Area M16 connectors IP 67 serie 423

Pole 7
Article number 99 5625 79 07

Item description

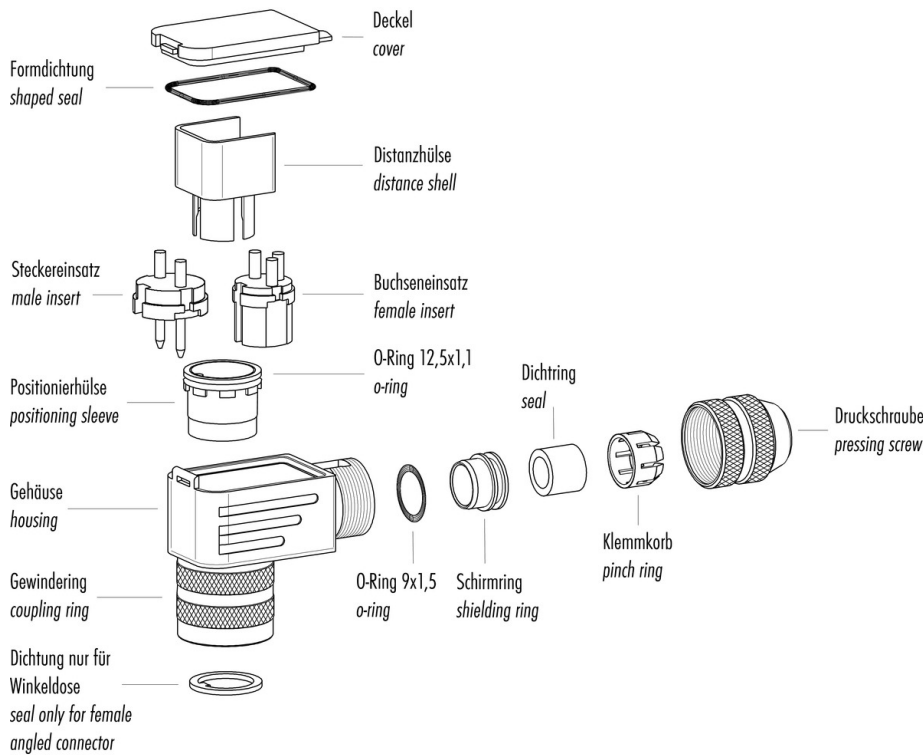

Installation instructions / Mounting cutout

Winkelversion

1. Dichtungen montieren (3x).
2. Kabelteile auffädeln.
3. Kabel und Schirm abmanteln.
4. Litzen durch das Gehäuse fädeln.
5. Schirmring, Klemmkorb montieren.
6. Druckschraube leicht andrehen.
7. Litzen an Kontakteinsatz löten.
8. Verdrehhülse in Winkelstellung montieren.
9. Kontakteinsatz, Distanzhülse einsetzen.
10. Deckel einhaken.
11. Druckschraube festziehen (ca. 10-20 Nm).

Angled version

1. Assemble sealing rings (3x).
2. Bead cable parts.
3. Dismantle cable and shielding braid.
4. Push single wires through housing.
5. Mount shielding ring and pinch ring.
6. Slightly fix pressing screw.
7. Solder wires to insert.
8. Mount positioning sleeve in angled position.
9. Put in insert and distance sleeve.
10. Mount lid.
11. Fix pressing screw (approx. 10-20 Nm).

