

Product Area Male cable connector IP 67, shielded
Push-Pull connectors

serie 430

Pole 8
Article number 99 4929 00 08

illustration



scale drawing

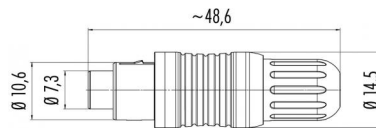

Contact Arrangement

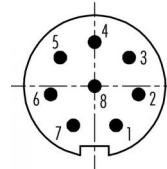

	X	Y
1	0,90	-1,65
2	1,85	-0,35
3	1,45	1,20
4	0,00	1,85
5	-1,45	1,20
6	-1,85	-0,35
7	-0,90	-1,65
8	0,00	0,00

You can find the item description and assembly instruction on the next page.

Technical data

Common values

Connector Design	Male cable connector
Connector locking system	Push-Pull locking
Termination	solder
Wire gauge (mm)	0,14 mm ²
Wire gauge (AWG)	26
Cable outlet	3,5 - 5 mm
Upper temperature	+85 °C
Lower temperature	-40 °C

Electrical values

Rated voltage	125 V
Rated impulse voltage	1500 V
Pollution degree	2
Overvoltage category	I
Material group	II
Rated current (40°C)	1 A
Volume resistivity	≤ 5 mΩ
EMV compliance	shieldable
Degree of protection	IP 67
Mechanical operation	>500 mating cycles

Material

Material of contact	CuZn (brass)
Contact plating	Au (gold)
Material of contact body	PBT, PA
Material of housing	PA

Cable data

material housing	-
insulation single lead	-
single lead structure	-
conductor resistance	-

Contacts 8, Male cable connector IP 67, shielded

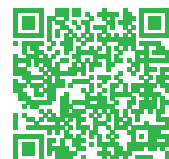

Product Area	Male cable connector IP 67, shielded Push-Pull connectors	serie 430	Pole	8
			Article number	99 4929 00 08

Item description

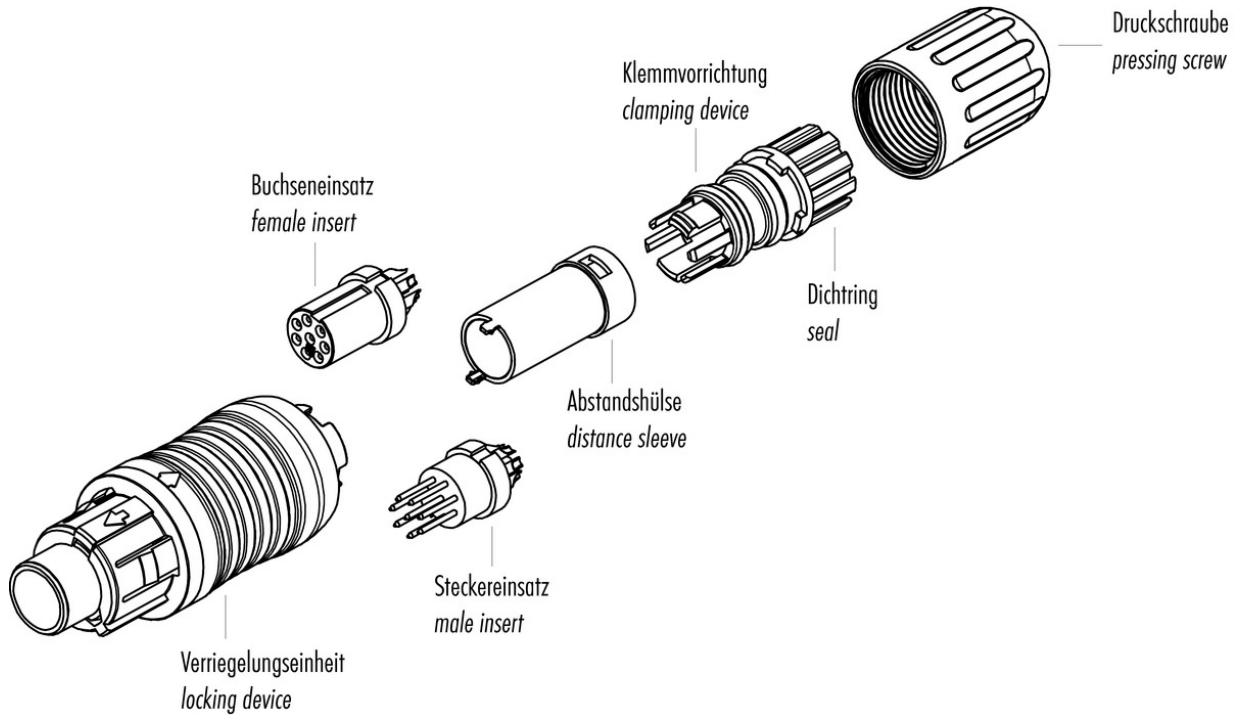

Installation instructions / Mounting cutout

1. Abmonteln auf L = 26mm.
Ummantelung nicht abstreifen.
2. Druckschraube und Dichtung am Kabel aufhängen.
Dichtung in Klemmvorrichtung montieren.
Ummantelung entfernen.
3. Abschirmung auffächern und ausklimmen.
4. Litzen isolieren und verzinnen.
5. Abstandshülse und Klemmvorrichtung veransten.
6. Einsätze anlöten.
7. Abstandshülse auf Hülse stecken.
8. Klemmvorrichtung vorschieben und einrasten.
Die Abschirmfäden in der Krone rundherum einfädeln.
9. Abschirmfäden in Richtung Abschirmung abstreifen und kürzen.
zu lang: Litzen auf Dichttring - undicht
zu kurz: kein Kontakt zu Wellenring
10. Montierte Einheit in Trägerhülse stecken.
Druckschraube aufstecken und festziehen.

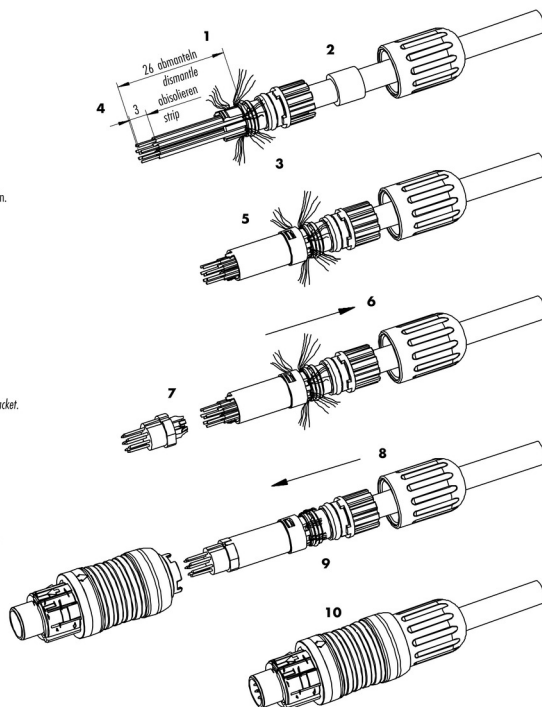

1. Strip to 26mm length but do not take off cable jacket.
2. Bend pressing screw and clamp device to cable.
Mount sealing ring to clamp device. Remove cable jacket.
3. Fan out and comb shielding braid.
4. Strip the insulation off the wires and tin them.
5. Snap in distance sleeve and clamp device.
6. Solder wires to solder cups.
7. Stick distance sleeve to sleeve.
8. Push forward and snap in clamp device.
Mount shielding braid around the crown.
9. Strip off and shorten shielding braid in the direction of the shielding ring.
too long: shielding braid on sealing ring - untight
too short: no contact to wave washer
10. Stick assembled unit into carrier sleeve and tighten pressing screw.