

Product Male cable connector, shieldable  
Area Push-Pull connectors IP 67

serie 440

Pole 12  
Article number 99 4833 00 12

illustration



scale drawing

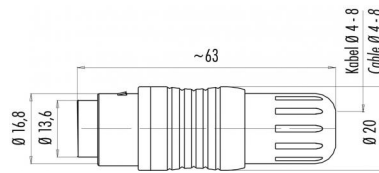

Contact Arrangement

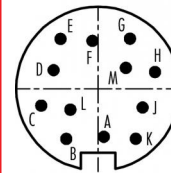

	X	Y
A	0,41	-3,45
B	-2,29	-3,61
C	-4,10	-1,21
D	-3,20	1,34
E	-2,71	3,59
F	-0,41	3,45
G	2,29	3,61
H	4,10	1,21
J	3,20	-1,34
K	2,71	-3,59
L	-2,00	-1,51
M	2,00	1,51

You can find the item description and assembly instruction on the next page.

Technical data

Common values

Connector Design	Male cable connector
Connector locking system	Push-Pull locking
Termination	solder
Wire gauge (mm)	0,25 mm <sup>2</sup>
Wire gauge (AWG)	24
Cable outlet	4 - 8 mm
Upper temperature	+85 °C
Lower temperature	-40 °C

Material

Material of contact	CuZn (brass)
Contact plating	Au (gold)
Material of contact body	PBT (UL 94 V-0)
Material of housing	PA GF 25 (UL 94 V-0)

Cable data

Contacts 12, male cable connector, shieldable

Electrical values

Rated voltage	60 V
Rated impulse voltage	500 V
Pollution degree	1
Overvoltage category	I
Material group	III
Rated current (40°C)	3 A
Volume resistivity	≤ 3 mΩ
EMV compliance	shielded
Degree of protection	IP 67
Mechanical operation	>1000 mating cycles



Product Area	Male cable connector, shieldable Push-Pull connectors IP 67	serie 440	Pole	12
			Article number	99 4833 00 12

Item description

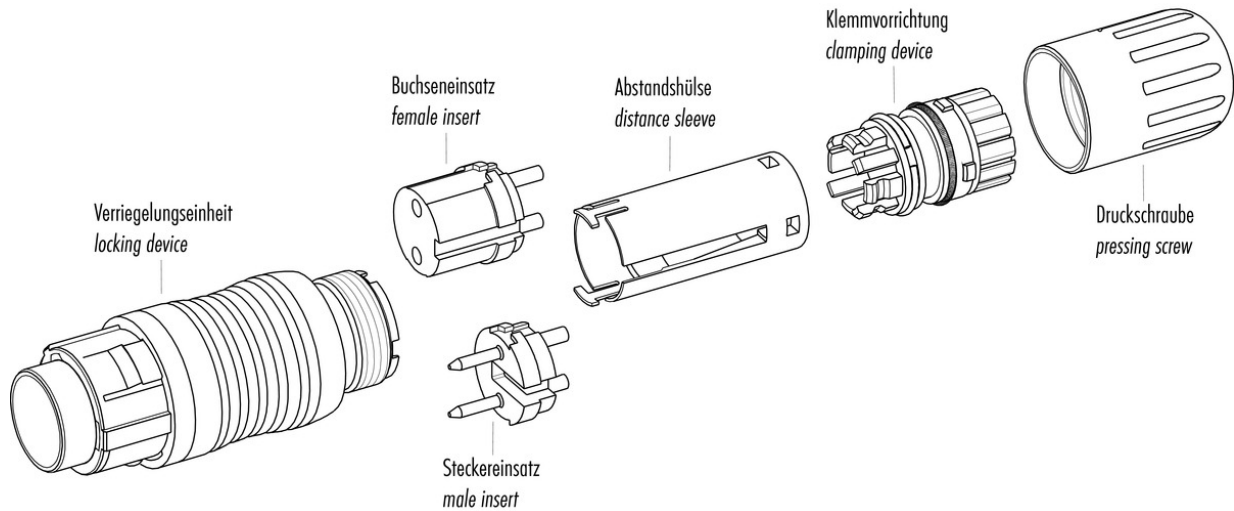

Installation instructions / Mounting cutout

1. Abmonteln auf L = 33mm. Ummantelung nicht abstreifen.
2. Druckschraube und Klemmvorrichtung auflöten. Ummantelung entfernen.
3. Litzen abisolieren und verzinnen.
4. Abschirmung aufwickeln und auskämmen. Die Abschirmfilzen in der Krone rundum einfädeln.
5. Abstandshülse und Klemmvorrichtung verzerren.
6. Gesteckte Einheit nach hinten über Kabel schieben (ca. 10mm).
7. Einsätze anlöten.
8. Gesteckte Einheit nach vorne schieben bis sie in den Kontakteinsatz einrastet.
9. Abschirmfilzen in Richtung Abschirmung abstreifen und kürzen. zu lang: Litzen auf Dichtung - undicht zu kurz: kein Kontakt zu Wellenring
10. Montierte Einheit in Trägerhülse stecken und Druckschraube festziehen.

1. Strip to 33mm length but do not take off cable jacket.
2. Bend pressing screw and clamp device. Remove cable jacket.
3. Strip the insulation off the wires and tin them.
4. Fan shielding braid and comb out. Thread wires around top.
5. Lock distance sleeve and clamp device.
6. Push mated units backwards over cable (approx. 10mm).
7. Solder inserts.
8. Push mated units forward until snap-in to contact insert.
9. Strip wires towards shielding ring and shorten. too long: wires on sealing ring - not tight too short: no contact to wave washer
10. Push assembled unit into carrier sleeve and tighten pressing screw.

