

Product Area	Male cable connector, shieldable Push-Pull connectors IP 67	serie 440	Pole Article number	6 DIN 99 4817 00 06
--------------	--	-----------	---------------------	------------------------

illustration

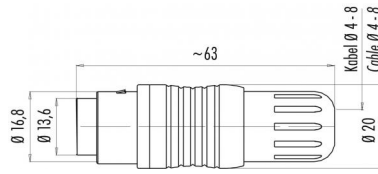

scale drawing



Contact Arrangement

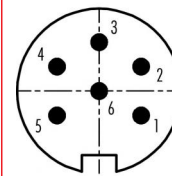

	X	Y
1	3,03	-1,75
2	3,03	1,75
3	0,00	3,50
4	-3,03	1,75
5	-3,03	-1,75
6	0,00	0,00

You can find the item description and assembly instruction on the next page.

Technical data

Common values

Connector Design	Male cable connector
Connector locking system	Push-Pull locking
Termination	solder
Wire gauge (mm)	0,75 mm <sup>2</sup>
Wire gauge (AWG)	20
Cable outlet	4 - 8 mm
Upper temperature	+85 °C
Lower temperature	-40 °C

Material

Material of contact	CuZn (brass)
Contact plating	Au (gold)
Material of contact body	PBT (UL 94 V-0)
Material of housing	PA GF 25 (UL 94 V-0)

Cable data

Contacts 6 DIN, male cable connector, shieldable

Electrical values

Rated voltage	125 V
Rated impulse voltage	800 V
Pollution degree	1
Overvoltage category	I
Material group	III
Rated current (40°C)	5 A
Volume resistivity	≤ 3 mΩ
EMV compliance	shielded
Degree of protection	IP 67
Mechanical operation	>1000 mating cycles



Product Area Male cable connector, shieldable  
Push-Pull connectors IP 67

serie 440

Pole 6 DIN  
Article number 99 4817 00 06

Date: 2014-07-20 - Page 2 of 2

### Item description

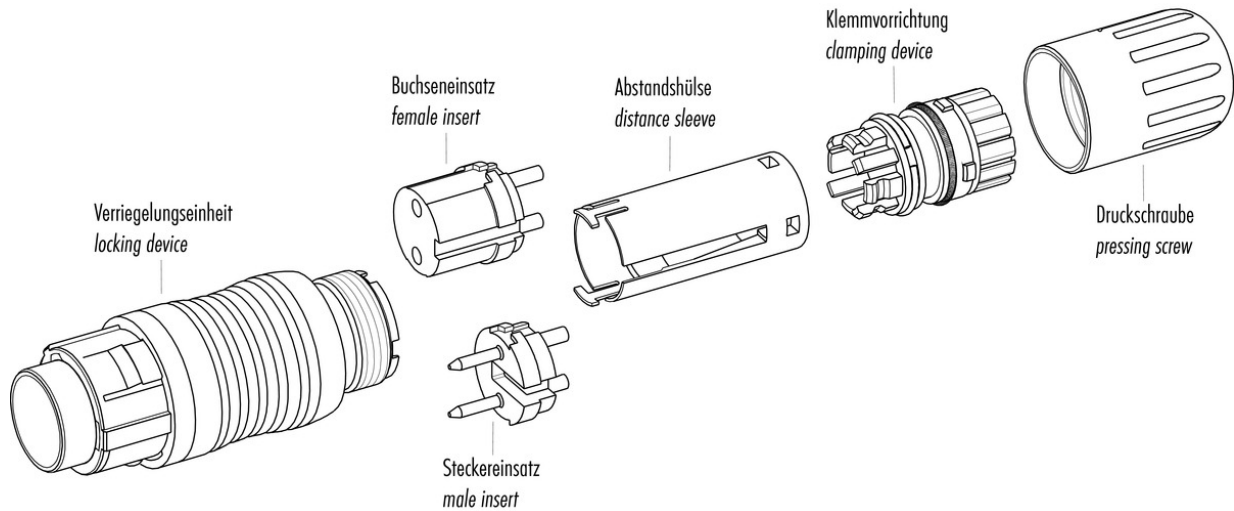

### Installation instructions / Mounting cutout

1. Abmonteln auf L = 33mm.  
Ummantlung nicht abstreifen.
2. Druckschraube und Klemmvorrichtung auflöten. Ummantlung entfernen.
3. Litzen abisolieren und verzinnen.
4. Abschirmung aufwickeln und auskämmen. Die Abschirmlitzen in der Krone rundum einfädeln.
5. Abstandshülse und Klemmvorrichtung verzerren.
6. Gesteckte Einheit nach hinten über Kabel schieben (ca. 10mm).
7. Einsätze anlöten.
8. Gesteckte Einheit nach vorne schieben bis sie in den Kontakteinsatz einrastet.
9. Abschirmlitzen in Richtung Abschirmung abstreifen und kürzen.  
zu lang: Litzen auf Dichtung - undicht  
zu kurz: kein Kontakt zu Wellenring
10. Montierte Einheit in Trägerhülse stecken und Druckschraube festziehen.

1. Strip to 33mm length but do not take off cable jacket.
2. Solder pressing screw and clamp device. Remove cable jacket.
3. Strip the insulation off the wires and tin them.
4. Fan shielding braid and comb out. Thread wires around top.
5. Lock distance sleeve and clamp device.
6. Push mated units backwards over cable (approx. 10mm).
7. Solder inserts.
8. Push mated units forward until snap-in to contact insert.
9. Strip wires towards shielding ring and shorten.  
too long: wires on sealing ring - not tight  
too short: no contact to wave washer
10. Push assembled unit into carrier sleeve and tighten pressing screw.

