

Product Area	Male cable connector Micro Push-Pull connectors	serie 420	Pole	3
			Article number	99 4705 00 03

illustration

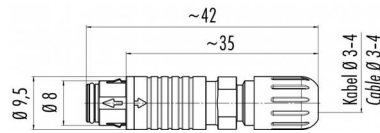

scale drawing



Contact Arrangement

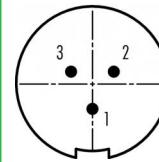

	X	Y
1	0,00	-1,35
2	1,17	0,68
3	-1,17	0,68

You can find the item description and assembly instruction on the next page.

Technical data

Common values

Connector Design	Male cable connector
Connector locking system	micro push-pull
Termination	solder
Wire gauge (mm)	0,14 mm <sup>2</sup>
Wire gauge (AWG)	26
Cable outlet	3 - 4 mm
Upper temperature	+80 °C
Lower temperature	-40 °C

Electrical values

Rated voltage	125 V
Rated impulse voltage	1500 V
Pollution degree	2
Overvoltage category	II
Material group	II
Rated current (40°C)	1 A
Volume resistivity	≤ 8 mΩ
EMV compliance	not shieldable
Degree of protection	IP 67
Mechanical operation	>1000 mating cycles

Material

Material of contact	CuZn (brass)
Contact plating	Au (gold)
Material of contact body	PA
Material of housing	PA

Cable data

material housing	-
insulation single lead	-
single lead structure	-
conductor resistance	-

Contacts 3, Male cable connector



Product  
Area Male cable connector  
Micro Push-Pull connectors

serie 420

Pole 3  
Article number 99 4705 00 03

Date: 2014-07-20 - Page 2 of 2

### Item description

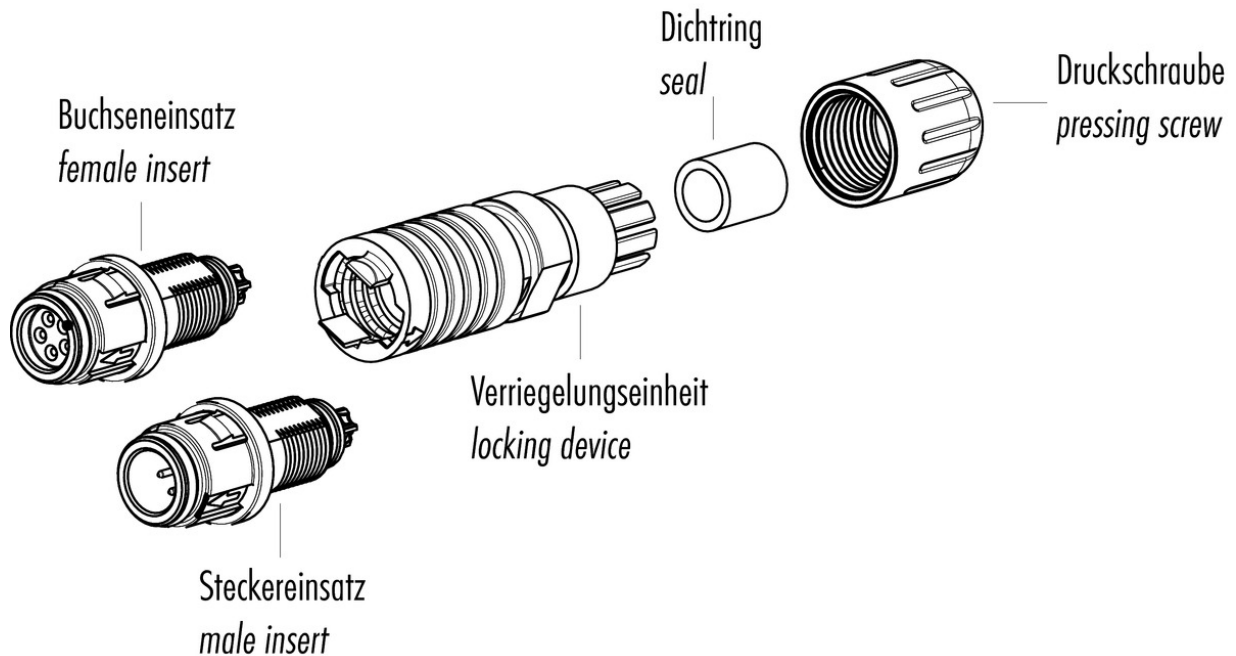

### Installation instructions / Mounting cutout

1. Abmanteln auf L = 9mm.  
Ummantlung abstreifen.
2. Dichtring in Klemmvorrichtung montieren.  
Druckschraube und Verriegelungseinheit auf Kabel  
auffädeln.
3. Litzen absisolieren (l = 3mm) und verzinnen.
4. Einsätze anlöten.
5. Verriegelungseinheit orientiert, Pfeilrichtung beachten,  
aufschieben und aufschrauben.
6. Druckschraube aufschieben und vor dem Festziehen  
an Schlüsselfläche kontorn.

(Bei Demontage zuerst Druckschraube öffnen)

1. Strip to 9mm length and remove cable jacket.
2. Mount sealing ring to clamp device to cable.  
Bead pressing screw and clamp device.
3. Strip the insulation off the wires (l = 3mm)  
and tin them.
4. Solder wires to solder cups.
5. Align locking unit, bear in mind direction of arrow,  
push forward and screw tightly.
6. Push pressing screw forward and secure them at flats.

(Before unmounting first open pressing screw.)

