

Product Male angled connector, cable outlet 6 - 10 mm (.24-.40 in.)
 Area M 23 connectors IP 67 serie 623

Pole 6
 Article number 99 4635 70 06

illustration



scale drawing

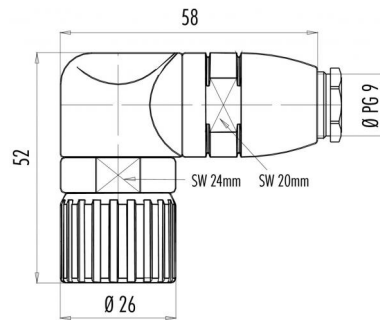

Contact Arrangement

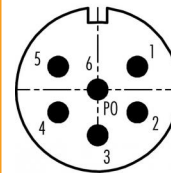

	X	Y
1	4,13	2,38
2	4,13	-2,38
3	0,00	-4,75
4	-4,13	-2,38
5	-4,13	2,38
6	0,00	0,00

You can find the assembly instruction on the next page.

Technical data

Common values

Connector Design	Male Coupling connector
Connector locking system	Screw
Termination	solder
Wire gauge (mm)	2,50 mm ²
Wire gauge (AWG)	14
Cable outlet	6 - 10 mm
Upper temperature	+125 °C
Lower temperature	-20 °C

Material

Material of contact	CuZn (brass)
Contact plating	Au (gold)
Material of housing	CUZn (brass nickel plated)

Cable data

Contacts 6, male coupling connector, shieldable, clockwise

Electrical values

Rated voltage	300 V
Rated impulse voltage	2500 V
Pollution degree	3
Overvoltage category	II
Material group	III
Rated current (40°C)	20 A
Volume resistivity	≤ 3 mΩ
EMV compliance	not shielded
Degree of protection	IP 67
Mechanical operation	> 50 mating cycles

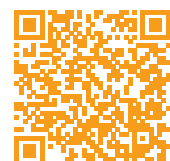

Product Male angled connector, cable outlet 6 - 10 mm (.24-.40 in.)
Area M 23 connectors IP 67 serie 623

Pole 6
Article number 99 4635 70 06

Date: 2014-07-20 - Page 2 of 2

Installation instructions / Mounting cutout

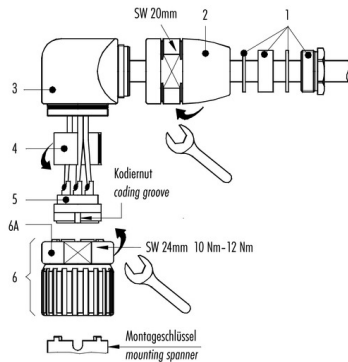

- Kabelverschraubung Pos. 1, Adapter Pos. 2 und Winkelkörper Pos. 3 auf das Kabel schieben.
- Kabel-Außenmantel 30 mm absolieren.
- Folie, Füller und innere Isolierungen abschneiden.
- Litzen 3,5 mm absolieren, verdrehen und verzinnen.
- Litzen an Kontakte löten, crimpen oder schrauben.
- Distanzhülse Pos. 4 einfügen.
- Einsatz Pos. 5 und Distanzhülse Pos. 4 in Einheit Pos. 6 einführen. Hierbei ist zu beachten, daß die gewünschte Kodiumut des Einsatzes Pos. 5 in den Kodiersteg eingeführt wird.
- Gesamte Einheit in Winkelkörper einführen (Achtung: acht Kodiermöglichkeiten) und mit Mutter Pos. 6A sichern (Anzugsdrehmoment: 10 Nm bis 12 Nm).
- Adapter Pos. 2 Festschrauben auf Anschlag.
- Kabelverschraubung Pos. 1 Festschrauben.

Anzugsdrehmoment für Klemmschraube Kontakteinsatz Pos. 5 mit Schraubkontakten beachten:

- max. 0,1 Nm für Schraubkontakte Steckdurchmesser 1 mm
- max. 0,2 Nm für Schraubkontakte Steckdurchmesser 2 mm

- Push the cable screw connection (1), adapter (2) and angled housing (3) onto the cable.
- Strip the cable coating by 30 mm.
- Trim foil, filler and inner insulation.
- Strip the single wires by 3.5 mm, twist and tin.
- Solder, crimp or screw the single wires to the contacts.
- Insert the distance shell (4).
- Guide the insert (5) and distance shell (4) into the unit (6), mind that the desired coding groove of the insert (5) is pushed into the coding bar.
- Insert the entire unit into the angle housing (Attention: eight coding options) and secure with nut (6A) (torque: 10 Nm up to 12 Nm).
- Screw the adapter (2) as tight as possible.
- Screw the cable gland (1) as tight as possible.

Please note: torque for clamping screw for contact insert (5) with screw contacts:

- max. 0.1 Nm for screw contacts with mating dia. 1 mm
- max. 0.2 Nm for screw contacts with mating dia. 2 mm