

Product Female angled connector, cable outlet 6 - 10 mm (.24-.40 in.)
 Area M 23 connectors IP 67 serie 623

Pole 16
 Article number 99 4610 70 16

illustration



scale drawing

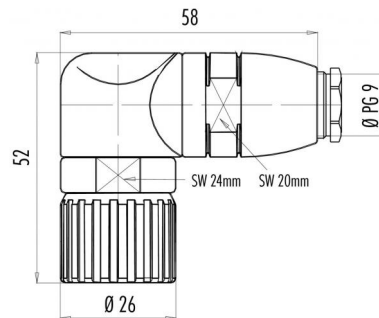

Contact Arrangement

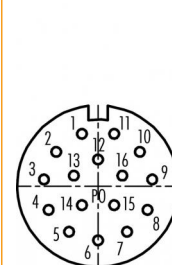

	X	Y
1	-1,70	5,50
2	-4,40	3,60
3	-5,70	0,70
4	-5,20	-2,50
5	-3,05	-4,80
6	0,00	-5,70
7	3,05	-4,80
8	5,20	-2,50
9	5,70	0,70
10	4,40	3,60
11	1,70	5,50
12	0,00	2,80
13	-2,55	1,10
14	-1,70	-2,00
15	1,70	-2,00
16	2,55	1,10

You can find the assembly instruction on the next page.

Technical data

Common values

Connector Design	Female Coupling connector
Connector locking system	Screw
Termination	solder
Wire gauge (mm)	1,00 mm ²
Wire gauge (AWG)	18
Cable outlet	6 - 10 mm
Upper temperature	+125 °C
Lower temperature	-20 °C

Material

Material of contact	CuSn (bronze)
Contact plating	Au (gold)
Material of housing	CUZn (brass nickel plated)

Cable data

Contacts: 16, female angled connector, cable outlet 6 - 10 mm, clockwise

Electrical values

Rated voltage	150 V
Rated impulse voltage	1500 V
Pollution degree	3
Overvoltage category	II
Material group	III
Rated current (40°C)	8 A
Volume resistivity	≤ 3 mΩ
EMV compliance	not shielded
Degree of protection	IP 67
Mechanical operation	> 50 mating cycles

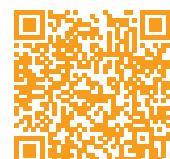

Product Female angled connector, cable outlet 6 - 10 mm (.24-.40 in.)
Area M 23 connectors IP 67 serie 623

Pole 16
Article number 99 4610 70 16

Date: 2014-07-20 - Page 2 of 2

Installation instructions / Mounting cutout

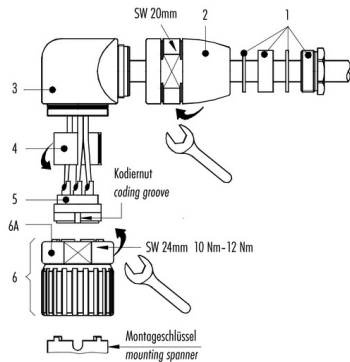

- Kabelverschraubung Pos. 1, Adapter Pos. 2 und Winkelkörper Pos. 3 auf das Kabel schieben.
- Kabel-Außenmantel 30 mm absolieren.
- Folie, Füller und innere Isolierungen abschneiden.
- Litzen 3,5 mm absolieren, verdrehen und verzinnen.
- Litzen an Kontakte löten, crimpen oder schrauben.
- Distanzhülse Pos. 4 einfügen.
- Einsatz Pos. 5 und Distanzhülse Pos. 4 in Einheit Pos. 6 einführen. Hierbei ist zu beachten, daß die gewünschte Kodiernut des Einsatzes Pos. 5 in den Kodiersteg eingeführt wird.
- Gesamte Einheit in Winkelkörper einführen (Achtung: acht Kodiermöglichkeiten) und mit Mutter Pos. 6A sichern (Anzugsdrehmoment: 10 Nm bis 12 Nm).
- Adapter Pos. 2 Festschrauben auf Anschlag.
- Kabelverschraubung Pos. 1 Festschrauben.

Anzugsdrehmoment für Klemmschraube Kontakteinsatz Pos. 5 mit Schraubkontakten beachten:

- max. 0,1 Nm für Schraubkontakte Steckdurchmesser 1 mm
- max. 0,2 Nm für Schraubkontakte Steckdurchmesser 2 mm

- Push the cable screw connection (1), adapter (2) and angled housing (3) onto the cable.
- Strip the cable coating by 30 mm.
- Trim foil, filler and inner insulation.
- Strip the single wires by 3.5 mm, twist and tin.
- Solder, crimp or screw the single wires to the contacts.
- Insert the distance shell (4).
- Guide the insert (5) and distance shell (4) into the unit (6), mind that the desired coding groove of the insert (5) is pushed into the coding bar.
- Insert the entire unit into the angle housing (Attention: eight coding options) and secure with nut (6A) (torque: 10 Nm up to 12 Nm).
- Screw the adapter (2) as tight as possible.
- Screw the cable gland (1) as tight as possible.

Please note: torque for clamping screw for contact insert (5) with screw contacts:

- max. 0.1 Nm for screw contacts with mating dia. 1 mm
- max. 0.2 Nm for screw contacts with mating dia. 2 mm