

Product Area	Male socket with wires, front fastened, unassembled M12 connectors A-Coding serie 713/763	Pole	5
		Article number	99 3441 216 05

illustration

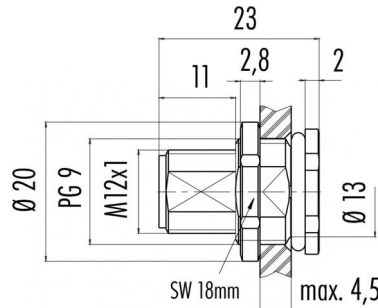

scale drawing



Contact Arrangement

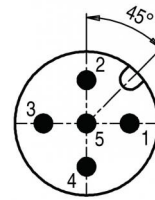

	X	Y
1	2,50	0,00
2	0,00	2,50
3	-2,50	0,00
4	0,00	-2,50
5	0,00	0,00

You can find the assembly instruction on the next page.

Technical data

Common values

Connector Design	Male socket
Connector locking system	Screw
Termination	solder
Wire gauge (mm)	0,25 mm <sup>2</sup>
Wire gauge (AWG)	24
Upper temperature	+85 °C
Lower temperature	-40 °C

Material

Material of contact	CuZn (brass)
Contact plating	Au (gold)
Material of contact body	PA
Material of housing	zinc diecasting, nickel plated

Cable data

Contacts 5: Male socket with wires, front fastened, unassembled, PG 9

Electrical values

Rated voltage	125 V
Rated impulse voltage	1500 V
Pollution degree	3
Overvoltage category	II
Material group	II
Rated current (40°C)	4 A
Volume resistivity	≤ 3 mΩ
Degree of protection	IP 68
Mechanical operation	>100 mating cycles

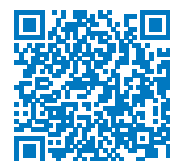

Product Area Male socket with wires, front fastened, unassembled  
M12 connectors A-Coding serie 713/763

Pole 5  
Article number 99 3441 216 05

Date: 2014-07-20 - Page 2 of 2

Installation instructions / Mounting cutout

Mit Fläche als Verdrehschutz  
With flats as anti-rotation device



Mit Durchgangsbohrung  
With bore hole



	c
PG 9	15,3
M16x1,5	16,1

Anzugsdrehmoment/Tightening moment

Metallgehäuse/Metal housing 6,25 Nm  
Kunststoffgehäuse/Plastic housing 3,75 Nm