

Product	Male cable connector shieldable, with wire clamp connection, iris type spring, with Diecasted Zinc Thread Ring	Pole	4
Area	M12 connectors A-Coding	Article number	99 1527 814 04
	serie 713		

illustration

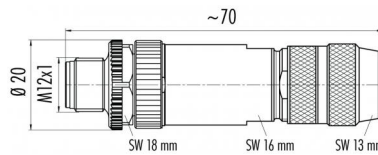

scale drawing



Contact Arrangement

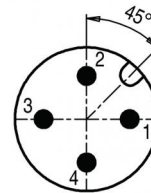

	X	Y
1	2,50	0,00
2	0,00	2,50
3	-2,50	0,00
4	0,00	-2,50

Attenuation characteristic

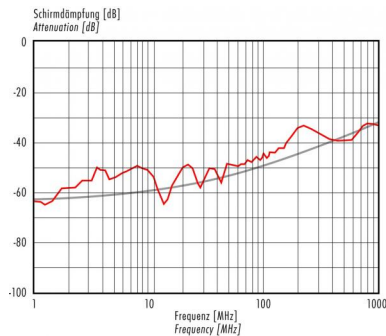

You can find the item description and assembly instruction on the next page.

Technical data

Common values

Connector Design	Male cable connector
Connector locking system	Screw
Termination	wire clamp
Wire gauge (mm)	0,50 mm ²
Wire gauge (AWG)	20
Cable outlet	5 - 8 mm
Upper temperature	+85 °C
Lower temperature	-40 °C

Material

Material of contact	CuSn (bronze)
Contact plating	Au (gold)
Material of contact body	PA
Material of housing	zinc diecasting, nickel plated

Cable data

Contacts 4: cable outlet: 5-8 mm, Male cable connector shieldable, with wire clamp connection, iris type spring, with Diecasted Zinc Thread Ring

Electrical values

Rated voltage	250 V
Rated impulse voltage	2500 V
Pollution degree	3
Overvoltage category	II
Material group	III
Rated current (40°C)	4 A
Volume resistivity	≤ 3 mΩ
Degree of protection	IP 67
Mechanical operation	>100 mating cycles



Product	Male cable connector shieldable, with wire clamp connection, iris type spring, with Diecasted Zinc Thread Ring	Pole	4
Area	M12 connectors A-Coding	serie 713	Article number 99 1527 814 04

Item description

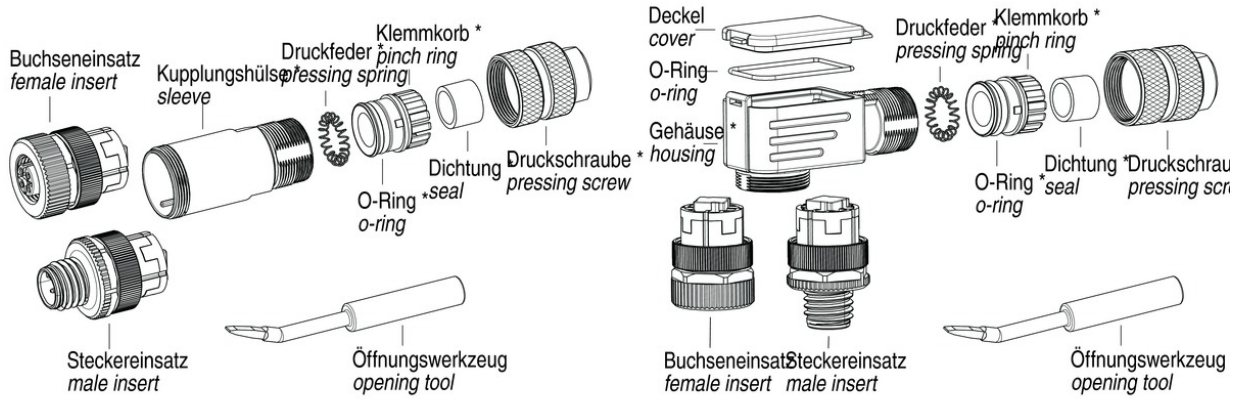

* Teile vormontiert
Premounted parts

Installation instructions / Mounting cutout

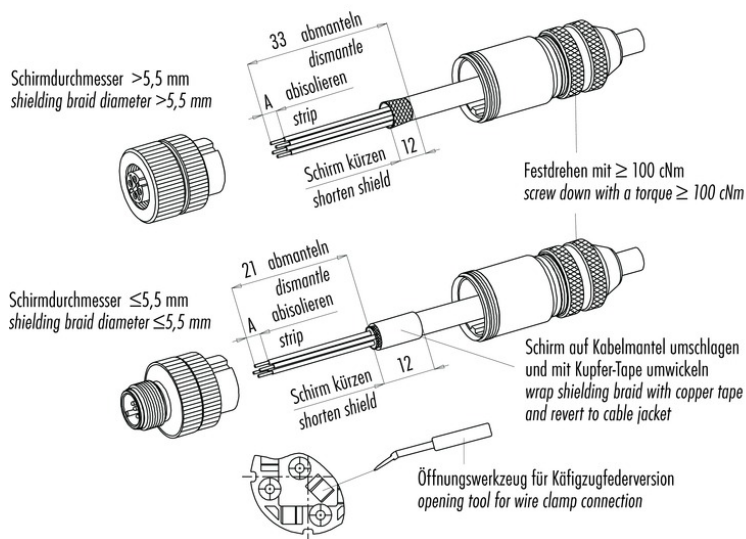

	Schraubklemmversion screw connection	Käfigzugfederversion wire clamp connection
Maß A/mm measure A/mm	5	7