

Product Area cable plug connector, screw terminal connection, static ring version
M12 connectors A-Coding serie 713

Pole 8
Article number 99 1487 914 08

illustration



scale drawing

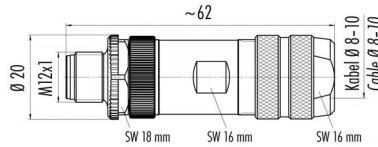

Contact Arrangement

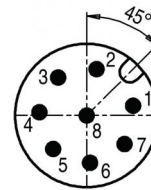

	X	Y
1	2,69	0,57
2	0,57	2,69
3	-1,66	2,20
4	-2,75	0,19
5	-1,94	-1,94
6	0,19	-2,74
7	2,20	-1,66
8	0,00	0,00

Attenuation characteristic

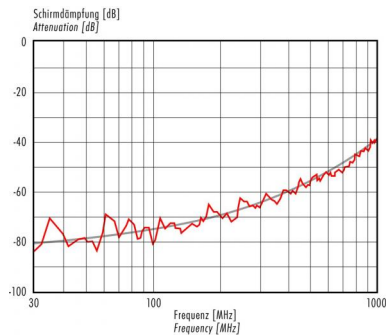

You can find the item description and assembly instruction on the next page.

Technical data

Common values

Connector Design	Male cable connector
Termination	screw
Wire gauge (mm)	0,50 mm ²
Wire gauge (AWG)	20
Cable outlet	8 - 10 mm
Upper temperature	+85 °C
Lower temperature	-40 °C

Material

Material of contact	CuZn (brass)
Contact plating	Au (gold)
Material of contact body	PA
Material of housing	brass, zinc diecasting, nickel plated

Cable data

Number of pins: 8, cable plug connector, cable gland 8 - 10 mm, screw terminal connection, static ring version

Electrical values

Rated voltage	60 V
Rated impulse voltage	800 V
Pollution degree	3
Overvoltage category	II
Material group	II
Rated current (40°C)	2 A
Volume resistivity	≤ 3 mΩ
Degree of protection	IP 67
Mechanical operation	>100 mating cycles



Product Area	cable plug connector, screw terminal connection, static ring version M12 connectors A-Coding serie 713	Pole Article number	8 99 1487 914 08
--------------	---	---------------------	---------------------

Item description

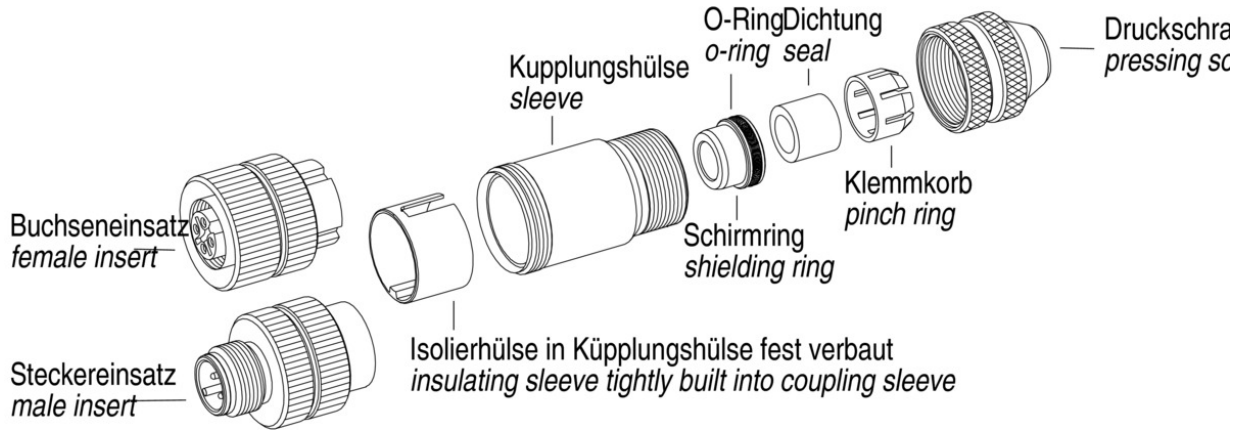

Installation instructions / Mounting cutout

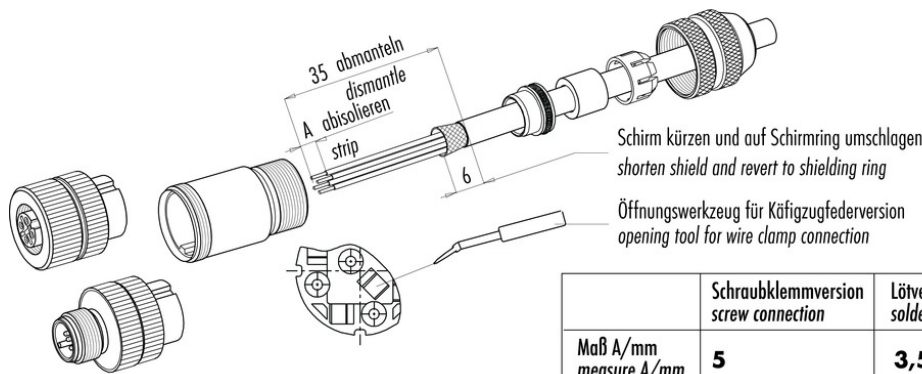

	Schraubklemmversion screw connection	Lötversion solder version	Käfigzugfederversion wire clamp connection
Maß A/mm measure A/mm	5	3,5	7