

Product	Male angled connector, shieldable, screw termination, iris type spring with Diecasted Zinc Thread Ring	Pole	5
Area	M12 connectors B-Coding serie 715	Article number	99 1439 820 05

illustration

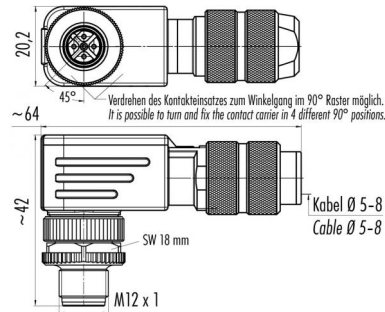

scale drawing



Contact Arrangement

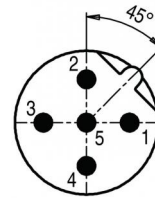

	X	Y
1	2,50	0,00
2	0,00	2,50
3	-2,50	0,00
4	0,00	-2,50
5	0,00	0,00

You can find the item description and assembly instruction on the next page.

Technical data

Common values

Connector Design	Male angled cable connector
Connector locking system	Screw
Wire gauge (mm)	0,75 mm ²
Wire gauge (AWG)	18
Cable outlet	5 - 8 mm
Upper temperature	+85 °C
Lower temperature	-40 °C

Material

Material of contact	CuZn (brass)
Contact plating	Au (gold)
Material of contact body	PA
Material of housing	PA/zinc diecasting, nickel plated, PA

Cable data

material housing	-
insulation single lead	-
single lead structure	-
conductor resistance	-
bending radius cable fixed	-
bending radius cable movable	-

Electrical values

Rated voltage	125 V
Rated impulse voltage	1500 V
Pollution degree	3
Overvoltage category	II
Material group	II
Rated current (40°C)	4 A
Volume resistivity	≤ 3 mΩ
Degree of protection	IP 67
Mechanical operation	>100 mating cycles

Cable outlet: 5 - 8, contacts: 5, male angled connector, shieldable, screw connection, iris type spring



Product	Male angled connector, shieldable, screw termination, iris type spring with Diecasted Zinc Thread Ring	Pole	5
Area	M12 connectors B-Coding serie 715	Article number	99 1439 820 05

Item description

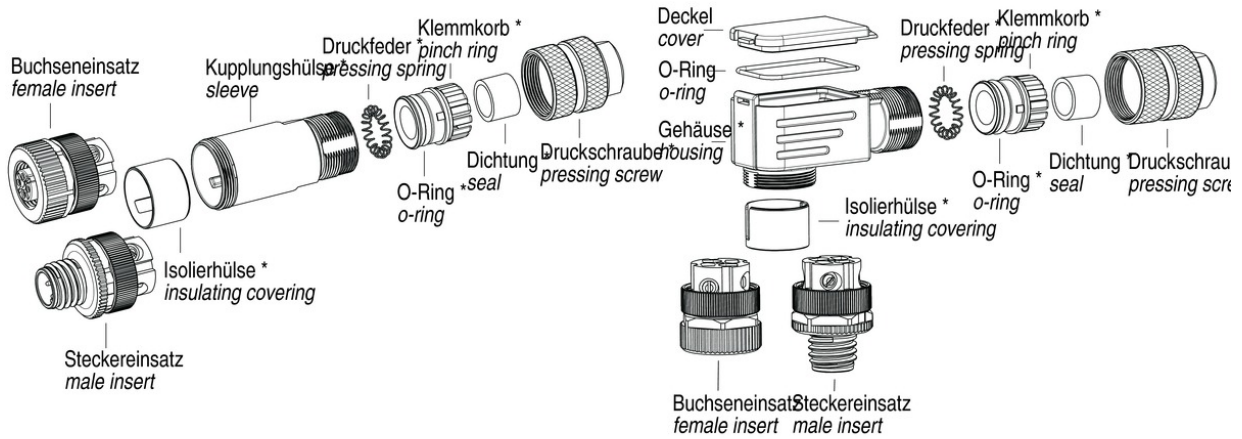

* Teile vormontiert
Premounted parts

Installation instructions / Mounting cutout

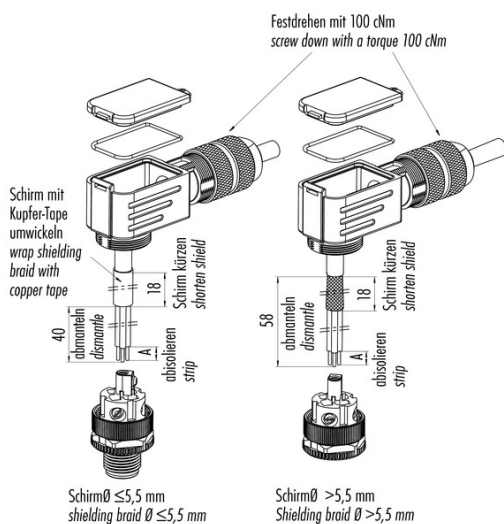

Schirmdurchmesser $\leq 5,5$ mm

- Gehäuse auf Kabel aufädeln.
- Abmanteln, absolieren, Schirm kürzen, Schirm auf Kabelmantel umschlagen und mit Kupfer-Tape umwickeln.
- Litzen anschließen.
- Gehäuse mit Stecker- bzw. Buchseneinsatz verschrauben.
- Kabel durch den Kabelabgang so weit zurückziehen, bis noch 2 mm vom Schirm sichtbar ist.
- Deckel mit Dichtung einsetzen und Druckschraube festdrehen.

Shield-diameter $\leq 5,5$ mm

- Bead housing to cable.
- Cut off cable coating, strip single cores, shorten shielding braid, revert to cable jacket and wrap it with copper tape.
- Connect single wires.
- Screw housing to male or female contact carrier.
- Pull back the cable through the outlet until only 2 mm of the shielding braid are visible.
- Mount lid with seal and fix pressing screw.

Schirmdurchmesser $> 5,5$ mm

- Gehäuse auf Kabel aufädeln.
- Abmanteln, absolieren, Schirm kürzen.
- Litzen anschließen.
- Gehäuse mit Stecker- bzw. Buchseneinsatz verschrauben.
- Kabel durch den Kabelabgang so weit zurückziehen, bis noch 2 mm vom Schirm sichtbar ist.
- Deckel mit Dichtung einsetzen und Druckschraube festdrehen.

Shield-diameter $> 5,5$ mm

- Bead housing to cable.
- Cut off cable coating, strip single cores, shorten shielding braid.
- Connect single wires.
- Screw housing to male or female contact carrier.
- Pull back the cable through the outlet until only 2 mm of the shielding braid are visible.
- Mount lid with seal and fix pressing screw.

	Schraubklemmversion screw connection	Käfigzugfeder- wire clamp connection
Maß A/mm measure A/mm	5	7

