

Product Female angled connector  
Area RD 30 connectors

serie 694

Pole 24  
Article number 99 0738 70 24

**Deratingkurven**

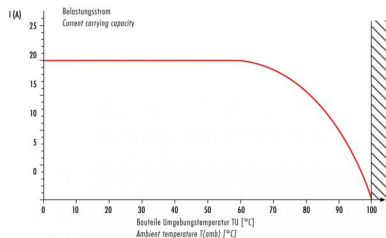

**illustration**



**scale drawing**

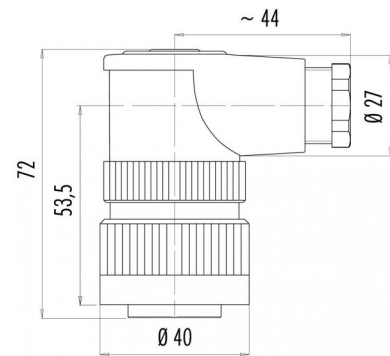

**Contact Arrangement**

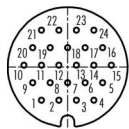

	X	Y
1	-5,25	-6,60
2	-1,75	-6,60
3	1,75	-6,60
4	5,25	-6,60
5	7,00	-3,10
6	3,50	-3,10
7	0,00	-3,10
8	-3,50	-3,10
9	-7,00	-3,10
10	-8,75	0,40
11	-5,25	0,40
12	-1,75	0,40
13	1,75	0,40
14	5,25	0,40
15	8,75	0,40
16	7,00	3,90
17	3,50	3,90
18	0,00	3,90
19	-3,50	3,90
20	-7,00	3,90
21	-5,25	7,40
22	-1,75	7,40
23	1,75	7,40
24	5,25	7,40

You can find the item description on the next page.

**Technical data**

**Common values**

Connector Design	Female angled cable connector
Connector locking system	Screw
Termination	solder
Wire gauge (mm)	0,25 mm <sup>2</sup>
Wire gauge (AWG)	24
Cable outlet	10 - 12 mm
Upper temperature	+100 °C
Lower temperature	-40 °C

**Material**

Material of contact	CuSn (bronze)
Contact plating	Au (gold)
Material of contact body	PA (UL 94 HB)
Material of housing	PA (UL 94 V-0)

**Cable data**

Contacts 24+PE, female angled connector,  
Cable outlet 10 - 12 mm

**Electrical values**

Rated voltage	125 V
Rated impulse voltage	2500 V
Pollution degree	3
Overvoltage category	III
Material group	III
Rated current (40°C)	3 A
Volume resistivity	≤ 3 mΩ
EMV compliance	not shielded
Degree of protection	IP 65
Mechanical operation	>500 mating cycles



Product Area Female angled connector RD 30 connectors

serie 694

Pole 24  
Article number 99 0738 70 24

Date: 2014-07-20 - Page 2 of 2

### Item description

1. Winkelkappe, Winkelhülse, Dichtung, Klemmkorb und Druckschraube auffädeln.
2. Kontakteinsatz in Gehäuse einclippen.
3. Leiter abmanteln, absolieren und anschließen.
4. Winkelhülse mit vormontiertem Gehäuse bis zum mechanischen Anschlag fest verschrauben.
5. Teile gemäß Darstellung montieren.

1. Bead angled hood, sleeve, seal, pinch ring and pressing screw.
2. Clip contact insert into housing.
3. Dismantle cable, strip wire and contact wires.
4. Strongly fasten angled sleeve with preassembled housing up to mechanical stop.
5. Mount remaining parts according to figure.

