

Product Area Female cable connector with IDT connection, contact surface gold
M12 connectors A-Coding serie 713

Pole 4
Article number 99 0528 14 04

illustration



scale drawing

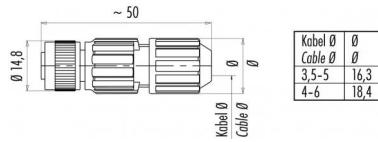

Contact Arrangement

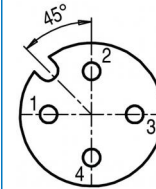

	X	Y
1	-2,50	0,00
2	0,00	2,50
3	2,50	0,00
4	0,00	-2,50

You can find the assembly instruction on the next page.

Technical data

Common values

Connector Design	Female cable connector
Connector locking system	Screw
Termination	IDT connection
Wire gauge (mm)	0,14-0,34 mm ²
Wire gauge (AWG)	26 - 18
Cable outlet	3.5 - 6 mm
Upper temperature	+80 °C
Lower temperature	-40 °C

Material

Material of contact	CuZn (brass)
Contact plating	Au (gold)
Material of contact body	PA
Material of housing	CuZn nickel-plated, PA

Cable data

Contacts 4: Female cable connector with IDT connection, contact surface gold, cable outlet: 0,14 - 0,34 mm Ø 3,5 - 6

Electrical values

Rated voltage	250 V
Rated impulse voltage	2500 V
Pollution degree	3
Overvoltage category	II
Material group	III
Rated current (40°C)	4 A
Volume resistivity	≤ 3 mΩ
Degree of protection	IP 67
Mechanical operation	>100 mating cycles

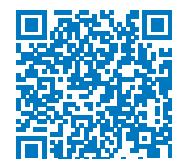

Product Area Female cable connector with IDT connection, contact surface gold
M12 connectors A-Coding serie 713

Pole 4
Article number 99 0528 14 04

Date: 2014-07-20 - Page 2 of 2

Installation instructions / Mounting cutout

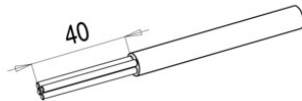

Ader-Ø incl. Isolation	Core-Ø incl. insulation	≤1,6mm
Kleinsten Draht-Ø der Ader	Smallest wire-Ø of core	0,5mm
Ø des Leitungsmantels	Ø of the conductor sheath	6,5mm
Aderisolation	Core insulation	PVC/PE
Anschlusstemperatur	Connecting temperature	-5°C – +50°C
Anschlussfrequenz	Termination frequency	10

- | | |
|--|---|
| <ol style="list-style-type: none"> 1. Leitungsummantelung entfernen (ca. 40mm). 2. Die Überwurfmutter bis zum Anschlag auf die Leitung aufstecken. 3. Adern in die gekennzeichneten Aderführungen einrasten. 4. Überstehende Aderenden bündig abschneiden. 5. Überwurfmutter auf den Kontaktträger aufstecken und mit Drehmoment (1,2 Nm) anziehen. | <ol style="list-style-type: none"> 1. Remove cable coating (approx. 40mm). 2. Slide the union nut onto the conductor as far as it will go. 3. Snap the cores into the marked core entries. 4. Cut off the core ends so that there is no overhang. 5. Push the cap nut onto the contact carrier and tighten with the necessary torque (1,2 Nm). |
|--|---|

Installation instructions / Mounting cutout

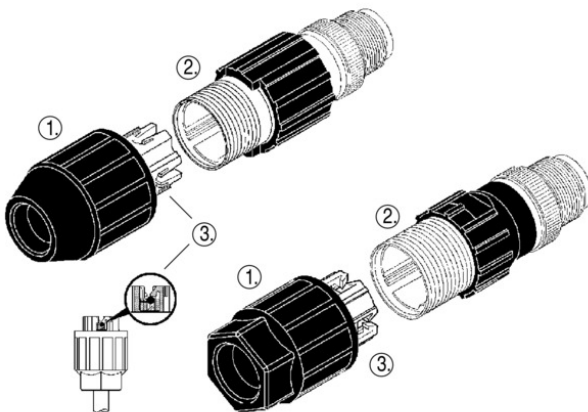

- | | |
|---|--|
| <ol style="list-style-type: none"> 1. Vormontierte Überwurfmutterereinheit (Überwurfmutter, Dichtung, Spleißring mit Zugentlastungskrone) 2. Kontaktträger 3. Spleißring | <ol style="list-style-type: none"> 1. Premounted cup nut unit (cap nut, seal, splice ring with strain relief) 2. Contact carrier 3. Splice ring |
|---|--|