

Product Area Flanschstecker, Power, Schraubklemmanschluss
M12 connectors A-Coding

serie 713/763 POWER

Pole 4
Article number 99 0431 500 04

illustration



scale drawing

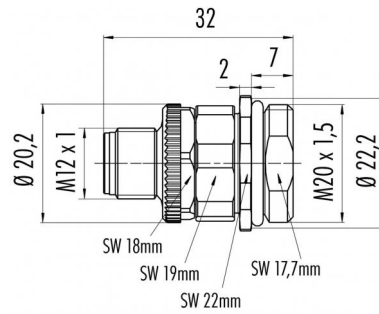

Contact Arrangement

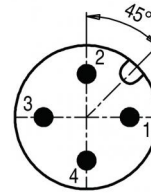

	X	Y
1	2,50	0,00
2	0,00	2,50
3	-2,50	0,00
4	0,00	-2,50

You can find the assembly instruction on the next page.

Technical data

Common values

Termination	screw clamp
Wire gauge (AWG)	16
Upper temperature	+85 °C
Lower temperature	-40 °C

Material

Material of contact body	PA
Material of housing	zinc diecasting, nickel plated

Cable data

Polzahl: 4, Flanschstecker, Power, Schraubklemmanschluss, Befestigungsgewinde M20 x 1,5

Electrical values

Rated voltage	250 V
Rated impulse voltage	2500 V
Pollution degree	3
Overvoltage category	II
Material group	II
Rated current (40°C)	8 A
Volume resistivity	≤ 3 mΩ
Degree of protection	IP 67
Mechanical operation	>100 mating cycles

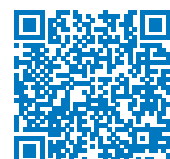

Product Flanschstecker, Power, Schraubklemmanschluss
Area M12 connectors A-Coding

serie 713/763 POWER

Pole 4
Article number 99 0431 500 04

Date: 2014-07-20 - Page 2 of 2

Installation instructions / Mounting cutout

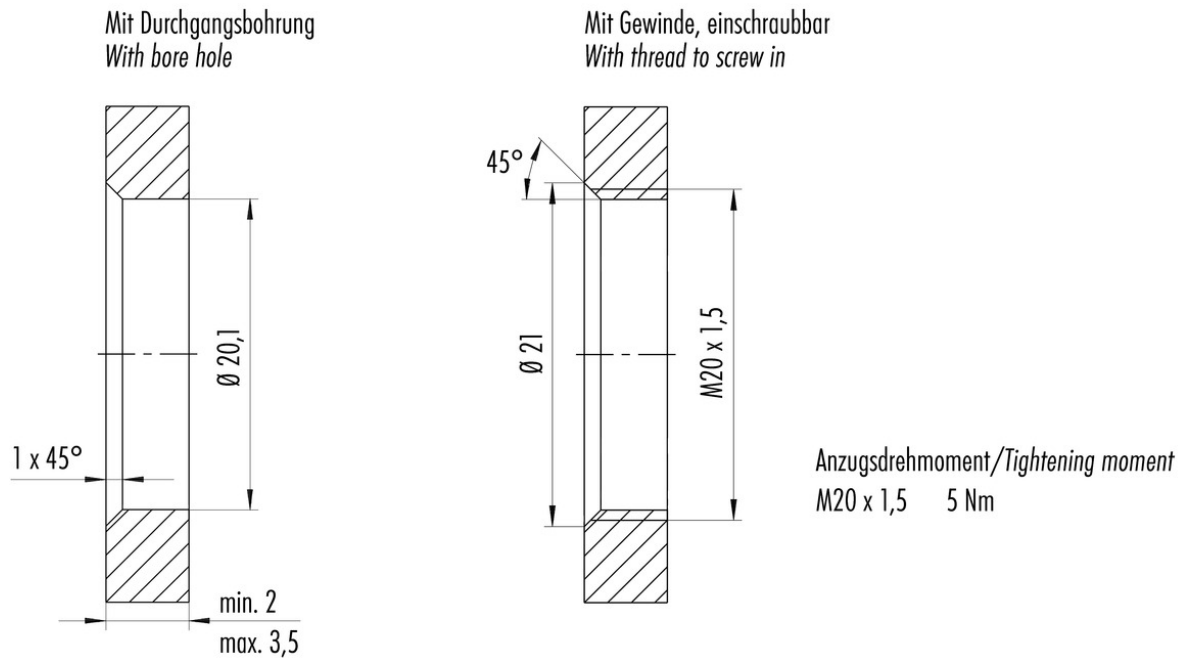

Installation instructions / Mounting cutout

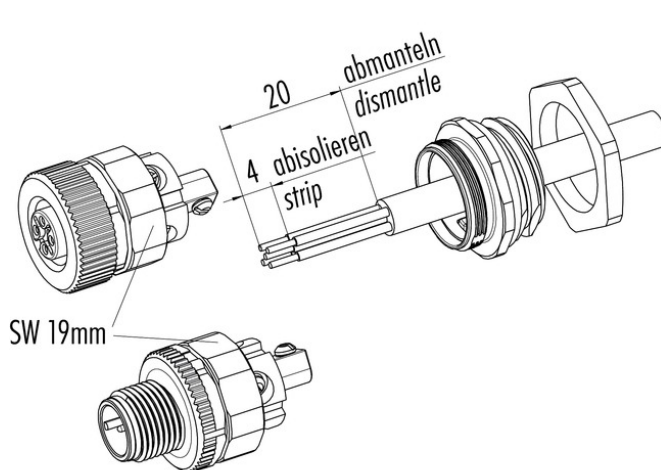

Litzenquerschnitt
Wire cross section

min. 0,14 mm ²	4-, 5-, 8-polig/contacts
max. 1,5 mm ²	4-, 5-polig/contacts
max. 0,5 mm ²	8-polig/contacts

Kontakteinsatz
Contact insert
4 x 90° verdrehbar/adjustable

Anzugsdrehmoment
Tightening torque
SW 19 Mutter/nut = 5 Nm M18 x 0,75
M20 x 1,5 = 5 Nm