

Product Area Flanschdose, Schraubklemmanschluss
M12 connectors A-Coding

serie 713/763

Pole 8
Article number 99 0382 500 08

illustration



scale drawing

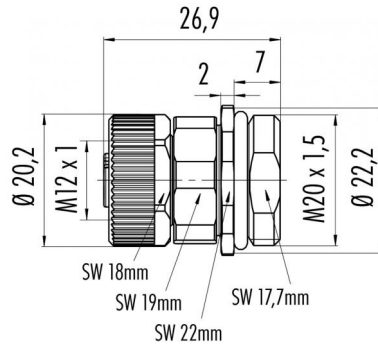

Contact Arrangement

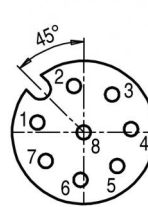

	X	Y
1	-2,69	0,57
2	-0,57	2,69
3	1,66	2,20
4	2,75	0,19
5	1,94	-1,94
6	-0,19	-2,75
7	-2,20	-1,66
8	0,00	0,00

You can find the assembly instruction on the next page.

Technical data

Common values

Termination screw clamp

Electrical values

Rated voltage 60 V
 Rated impulse voltage 800 V
 Pollution degree 3
 Overvoltage category II
 Material group II
 Rated current (40°C) 2 A
 Volume resistivity ≤ 3 mΩ

Material

Material of contact body PA
 Material of housing zinc diecasting, nickel plated,
 stainless steel 1.4404

Cable data

Polzahl: 8, Flanschdose,
 Schraubklemmanschluss, Befestigungsgewinde
 M20 x 1,5



Product Flanschdose, Schraubklemmanschluss
Area M12 connectors A-Coding

serie 713/763

Pole 8
Article number 99 0382 500 08

Date: 2014-07-20 - Page 2 of 2

Installation instructions / Mounting cutout

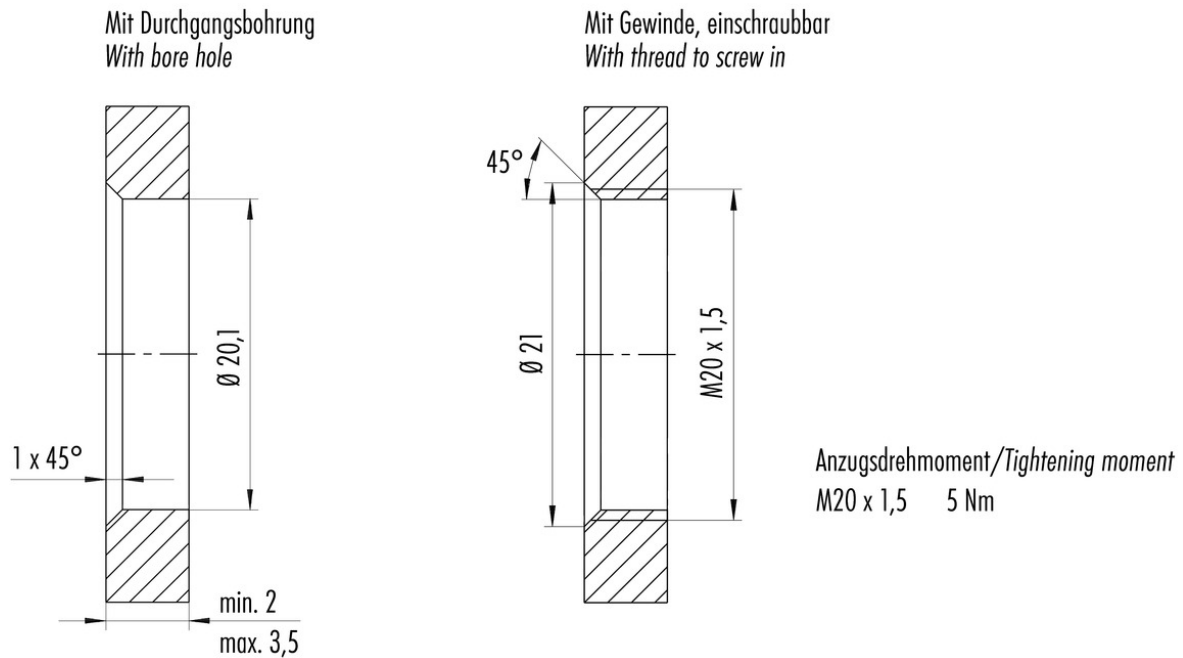

Installation instructions / Mounting cutout

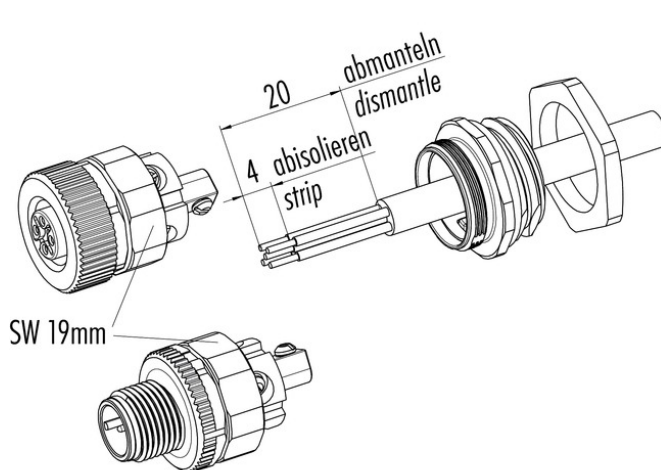

Litzenquerschnitt
Wire cross section
min. 0,14 mm² 4-, 5-, 8-polig/contacts
max. 1,5 mm² 4-, 5-polig/contacts
max. 0,5 mm² 8-polig/contacts

Kontakteinsatz
Contact insert
4 x 90° verdrehbar/adjustable

Anzugsdrehmoment
Tightening torque
SW 19 Mutter/nut = 5 Nm M18 x 0,75
M20 x 1,5 = 5 Nm