

Product Area	Female socket Micro Push-Pull connectors	serie 420	Pole	3
			Article number	09 4708 00 03

illustration

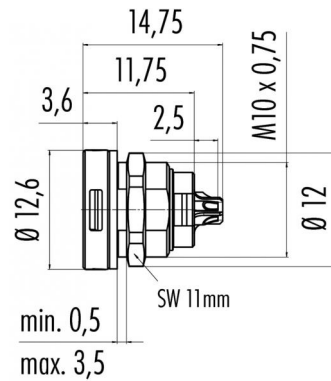

scale drawing



Contact Arrangement

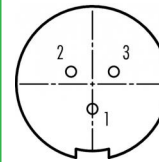

	X	Y
1	0,00	-1,35
2	-1,17	0,68
3	1,17	0,68

You can find the item description and assembly instruction on the next page.

Technical data

Common values

Connector Design	Female socket
Connector locking system	micro push-pull
Termination	solder
Wire gauge (mm)	0,14 mm <sup>2</sup>
Wire gauge (AWG)	26
Upper temperature	+80 °C
Lower temperature	-40 °C

Material

Material of contact	CuSn (bronze)
Contact plating	Au (gold)
Material of contact body	PA
Material of housing	PA

Cable data

material housing	-
insulation single lead	-
single lead structure	-
conductor resistance	-

Electrical values

Rated voltage	125 V
Rated impulse voltage	1500 V
Pollution degree	2
Overvoltage category	II
Material group	II
Rated current (40°C)	1 A
Volume resistivity	≤ 8 mΩ
EMV compliance	not shieldable
Degree of protection	IP 67
Mechanical operation	>1000 mating cycles

Contacts 3 Female socket



Product  
Area

Female socket  
Micro Push-Pull connectors

serie 420

Pole  
Article number

3  
09 4708 00 03

Date: 2014-07-20 - Page 2 of 3

Item description

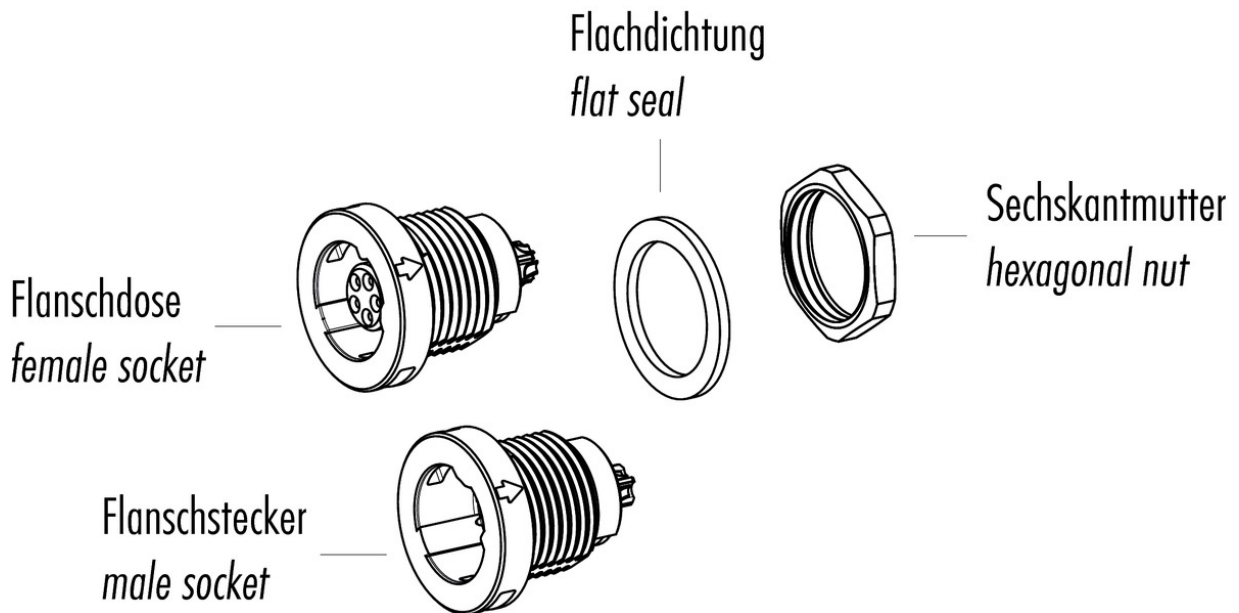

Installation instructions / Mounting cutout

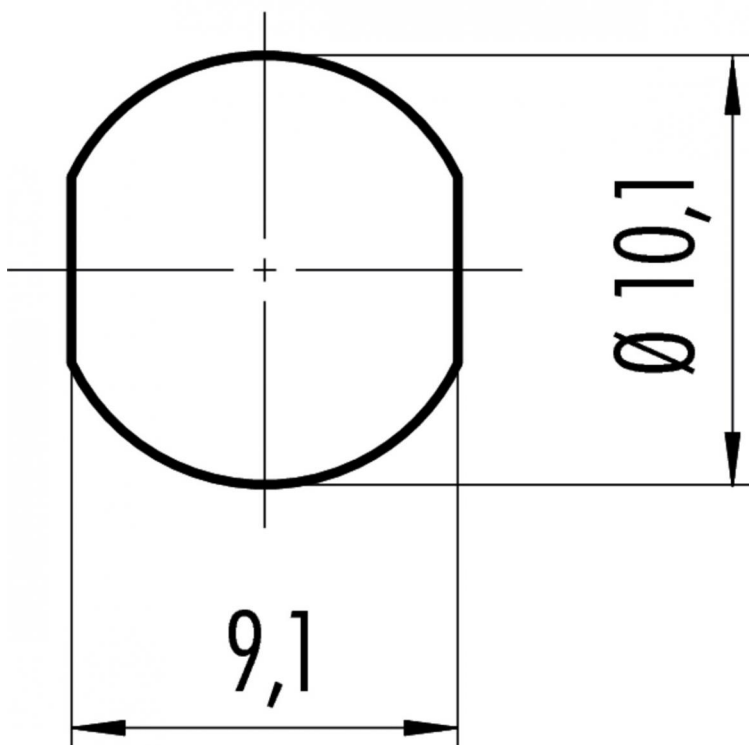

Product Area Female socket  
Micro Push-Pull connectors

serie 420

Pole 3  
Article number 09 4708 00 03

Date: 2014-07-20 - Page 3 of 3

### Installation instructions / Mounting cutout

1. Abmanteln auf L = 9mm.  
Ummantelung abstreifen.
2. Dichtring in Klemmvorrichtung montieren.  
Druckschraube und Verriegelungseinheit auf Kabel aufädeln.
3. Litzen abisolieren (l = 3mm) und verzinnen.
4. Einsätze anlöten.
5. Verriegelungseinheit orientiert, Pfeilrichtung beachten, aufschieben und aufschrauben.
6. Druckschraube aufschieben und vor dem Festziehen an Schlüsselfläche kontorn.

(Bei Demontage zuerst Druckschraube öffnen)

1. Strip to 9mm length and remove cable jacket.
2. Mount sealing ring to clamp device to cable.  
Bead pressing screw and clamp device.
3. Strip the insulation off the wires (l = 3mm) and tin them.
4. Solder wires to solder cups.
5. Align locking unit, bear in mind direction of arrow, push forward and screw tightly.
6. Push pressing screw forward and secure them at flats.

(Before unmounting first open pressing screw.)

