

Product Flanschdose, Frontmontage, mit Litzen
Area M8 connectors

serie 768/718

Pole 6
Article number 09 3422 86 06

illustration



scale drawing

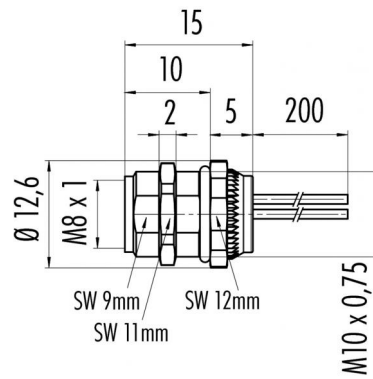

Contact Arrangement

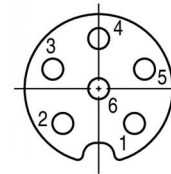

- 1 braun/brown
- 2 weiß/white
- 3 blau/blue
- 4 schwarz/black
- 5 grau/grey
- 6 rosa/pink

You can find the assembly instruction on the next page.

Technical data

Common values

Connector Design	Female socket
Wire gauge (mm)	0,14 mm ²
Wire gauge (AWG)	26
Upper temperature	+85 °C
Lower temperature	-40 °C

Material

Material of contact	CuSn (bronze)
Contact plating	Au (gold)
Material of contact body	PA (UL 94 HB)
Material of housing	zinc diecasting, nickel plated

Electrical values

Rated voltage	30 V
Rated impulse voltage	800 V
Pollution degree	3
Overvoltage category	II
Material group	II
Rated current (40°C)	1,5 A
Volume resistivity	≤ 3 mΩ
Degree of protection	IP 67
Mechanical operation	>100 mating cycles

Cable data

Number of pins: 6, flange socket, front mounting, with single leads



Product Flanschdose, Frontmontage, mit Litzen
Area M8 connectors

serie 768/718

Pole 6
Article number 09 3422 86 06

Date: 2014-07-20 - Page 2 of 2

Installation instructions / Mounting cutout

Mit Fläche als Verdrehenschutz
With flats as anti-rotation device

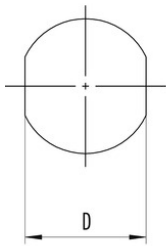

Mit Durchgangsbohrung
With bore hole

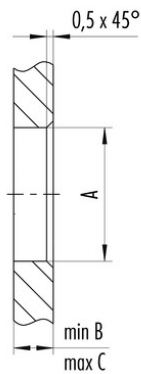

Mit Gewinde, einschraubbar
With thread to screw in

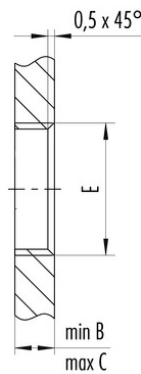

Gewinde E / thread E	A	B	C	D
M8 x 0,5	8,1	2,0	4,5	7,1
M10 x 0,75	10,1	2,0	6,5	9,1
M12 x 1	12,1	2,5	4,5	10,0

Anzugsdrehmoment/Tightening moment 1 Nm