

Product Area Flanschdose, Frontmontage, mit Litzen
M8 connectors

serie 768/718

Pole 3
Article number 09 3418 86 03

illustration



scale drawing

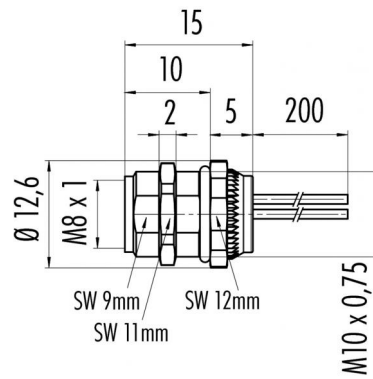

Contact Arrangement

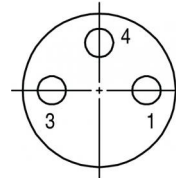

1 braun/brown
3 blau/blue
4 schwarz/blac

You can find the assembly instruction on the next page.

Technical data

Common values

Connector Design	Female socket
Termination	Single leads 0.25
Wire gauge (mm)	0,25 mm ²
Wire gauge (AWG)	24
Upper temperature	+85 °C
Lower temperature	-40 °C

Material

Material of contact	CuSn (bronze)
Contact plating	Au (gold)
Material of contact body	PA (UL 94 HB)
Material of housing	zinc diecasting, nickel plated

Electrical values

Rated voltage	60 V
Rated impulse voltage	800 V
Pollution degree	3
Overvoltage category	II
Material group	II
Rated current (40°C)	4 A
Volume resistivity	≤ 3 mΩ
Degree of protection	IP 67
Mechanical operation	>100 mating cycles

Cable data

Number of pins: 3, flange socket, front mounting, with single leads



Product Flanschdose, Frontmontage, mit Litzen
Area M8 connectors

serie 768/718

Pole 3
Article number 09 3418 86 03

Date: 2014-07-20 - Page 2 of 2

Installation instructions / Mounting cutout

Mit Fläche als Verdrehenschutz
With flats as anti-rotation device

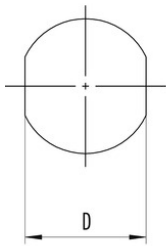

Mit Durchgangsbohrung
With bore hole

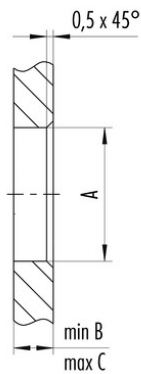

Mit Gewinde, einschraubbar
With thread to screw in

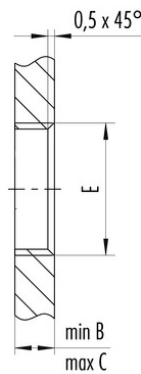

Gewinde E/thread E	A	B	C	D
M8 x 0,5	8,1	2,0	4,5	7,1
M10 x 0,75	10,1	2,0	6,5	9,1
M12 x 1	12,1	2,5	4,5	10,0

Anzugsdrehmoment/Tightening moment 1 Nm