

Product Male socket, fixing thread, PG 9, M16 x 0,5
Area M12 connectors A-Coding

serie 713/763

Pole 8
Article number 09 0381 387 08

illustration



scale drawing

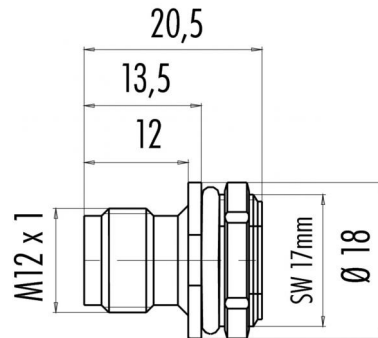

Contact Arrangement

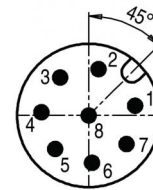

	X	Y
1	2,69	0,57
2	0,57	2,69
3	-1,66	2,20
4	-2,75	0,19
5	-1,94	-1,94
6	0,19	-2,74
7	2,20	-1,65
8	0,00	0,00

You can find the assembly instruction on the next page.

Technical data

Common values

Connector Design	Male socket
Connector locking system	Screw
Termination	solder
Wire gauge (mm)	0,25 mm ²
Wire gauge (AWG)	24
Upper temperature	+85 °C
Lower temperature	-40 °C

Material

Material of contact	CuZn (brass)
Contact plating	Au (gold)
Material of contact body	PA
Material of housing	PA

Cable data

Contacts 8: Male socket, fixing thread, M16 x 0,5

Electrical values

Rated voltage	60 V
Rated impulse voltage	800 V
Pollution degree	3
Overvoltage category	II
Material group	II
Rated current (40°C)	2 A
Volume resistivity	≤ 3 mΩ
Degree of protection	IP 67
Mechanical operation	>100 mating cycles



Product Male socket, fixing thread, PG 9, M16 x 0,5
Area M12 connectors A-Coding

serie 713/763

Pole 8
Article number 09 0381 387 08

Date: 2014-07-20 - Page 2 of 2

Installation instructions / Mounting cutout

Mit Fläche als Verdrehschutz
With flats as anti-rotation device

PG 9/M16 x 1,5

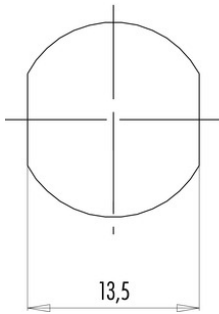

Mit Durchgangsbohrung
With bore hole

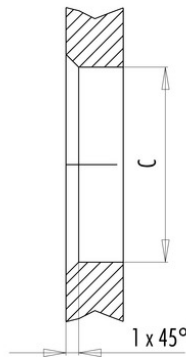

Mit Gewinde, einschraubbar
With thread to screw in

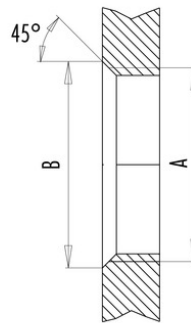

alternativ/alternativ

	A	B	C
PG 9	PG 9	16,2	15,3
PG 13,5	PG 13,5	21,5	20,5
M16x1,5	M16x1,5	17,0	16,1
M20x1,5	M20x1,5	21,0	20,1

Anzugsdrehmoment/Tightening moment

Metallgehäuse/Metal housing 6,25 Nm
Kunststoffgehäuse/Plastic housing 3,75 Nm